

# H-10 INSTALLATION INSTRUCTIONS AND SAFETY INFORMATION

FOR THE VIKING H-10 GATE OPERATOR



UL 325 CLASS I, CLASS II, CLASS III,  
AND CLASS IV COMPLIANT

**Residential and Commercial  
Vehicular Slide Gate Operator**



**VIKING WIRELESS**



**SOLAR EFFICIENT OPERATION**

VIKING ACCESS SYSTEMS™

VIKING ACCESS SYSTEMS™

VIKING ACCESS SYSTEMS™

# STANDARD FEATURES AND OPERATOR SPECIFICATIONS

- Externally accessible Manual Release Switch
- Plated and powder coated steel chassis
- Adjustable travel speed
- Up to 75' maximum gate opening
- 100% duty cycle
- Modular Power Supply Box for convenient low voltage installations
- 100 cycles of operation on backup battery (1000 lb. gate and 20' length)
- Intelligent speed control with smooth start and stop, self-adjust system
- Anti-Tailgate and Operation Pre-Warming features
- NEW: Smart Position Sensor tracks the exact gate position during power outages and when the gate is moved manually
- Hold Open Timer to automatically close the gate
- Intelligent obstruction detection with adjustable sensitivity
- Modular connectors for easy access control and accessory installation
- Regulated power supply for your external accessories
- LED indicators display gate and operator status for easy troubleshooting
- On-Board LCD Display provides diagnostics, operator status, settings and real-time volt and amp readings
- Built-in motor heater for cold weather applications
- Equipped for 115/230 VAC, 24 VAC/VDC and Solar power supplies

THE VIKING H-10™ SLIDE GATE OPERATOR

# TABLE OF CONTENTS:

<b>IMPORTANT SAFETY INFORMATION</b>	<b>2-9</b>
Important Safety Instructions.....	2
Important Installation Instructions.....	2-3
Maintenance.....	4
General Safety Precautions.....	4-5
UL325 Gate Operator Classifications.....	5
Monitored Entrapment Protection Requirements.....	6
Monitored Entrapment Protection Installation.....	7
Manual Release.....	7
Audible Alarm Reset Installation.....	8
Warning Placard Installation.....	9
<b>SPECIFICATIONS</b>	<b>10</b>
<b>CONTROL BOARD REFERENCES</b>	<b>11</b>
<b>GATE OPERATOR INSTALLATION</b>	<b>12-15</b>
Concrete Pad Option.....	12
Post Mounting Option.....	13
Operator Positioning.....	14-15
<b>ELECTRICAL INSTALLATION</b>	<b>16-18</b>
High Voltage Supply Option.....	16
Low Voltage Supply Option.....	17
Solar Supply Option.....	17
Monitored UL Sensor Connections.....	18
<b>LIMITS SETUP</b>	<b>19</b>
<b>PRIMARY/SECONDARY SET UP</b>	<b>20-21</b>
Two Wire Communication.....	20
Wireless Communication Options.....	21
<b>CONTROL BOARD SETUP</b>	<b>22-25</b>
Initial Settings.....	22-23
Obstruction Detection Sensor (ODS).....	24
Heater, Lock Mode.....	25
<b>ACCESSORY CONNECTIONS</b>	<b>26-33</b>
Access Control Connections.....	26-27
Radio Receiver.....	28
Photocell.....	29
Viking Loop Rack.....	30
Guidelines for Loop Installations.....	31
Magnetic Lock, Lock Solenoid.....	32
Barrier Arm Synchronization Option.....	33
<b>TROUBLESHOOTING</b>	<b>34-40</b>
LED References.....	34-35
LCD Display References.....	36-39
Solutions.....	40
<b>PARTS DIAGRAM/PARTS LIST</b>	<b>41</b>
<b>LIMITED WARRANTY</b>	<b>42-43</b>
<b>VIKING ACCESSORIES</b>	<b>44</b>

# IMPORTANT SAFETY INFORMATION

 **WARNING! Not Following these instructions may cause severe injury or death.**

## IMPORTANT SAFETY INSTRUCTIONS

 **WARNING! To reduce the risk of severe injury or death.**

1. READ AND FOLLOW ALL INSTRUCTIONS.
2. Never let children operate or play with gate controls. Keep the remote away from children.
3. Always keep people and objects away from the gate. **NO ONE SHOULD CROSS THE PATH OF THE MOVING GATE.**
4. Test the gate operator monthly. The gate **MUST** reverse on contact with a rigid object or when an object activates the non-contact sensors. After adjusting the force or the limit travel, retest the gate operator. Failure to adjust and retest the gate operator properly can increase the risk of injury or death.
5. Use the emergency release only when the gate is not moving.
6. **KEEP GATES PROPERLY MAINTAINED.** Read the user's manual. Have a qualified service person make repairs to gate hardware.
7. The entrance is for vehicles only. Pedestrians must use a separate entrance.
8. **Every gate operator installation MUST have secondary protection devices against entrapment, such as edge sensors and photo beams more in particularly in places where the risk of entrapment is more likely to occur.**
9. SAVE THESE INSTRUCTIONS.

## IMPORTANT INSTALLATION INSTRUCTIONS

1. Install the gate operator only when:
  - a. The operator is appropriate for the construction of the gate and usage Class of the gate (refer to page 5),
  - b. All openings of a horizontal slide gate are guarded or screened from the bottom of the gate to a minimum of 6 feet (1.83 m) above the ground to prevent a 2-1/4 inch (57.2 mm) diameter sphere from passing through the openings anywhere in the gate, and in that portion of the adjacent fence that the gate covers in the open position,
  - c. ALL EXPOSED PINCH POINTS ARE ELIMINATED OR GUARDED, AND
  - d. GUARDING IS SUPPLIED FOR EXPOSED ROLLERS. .
2. The operator is intended for installation only on gates used for vehicles. Pedestrians must be supplied with a separate access opening. For pedestrian access in the vicinity of an automated vehicular gate, separate pedestrian access shall be provided or available. The pedestrian access shall be in a location such that a pedestrian shall not come in contact with a moving vehicular access gate during the entire path of travel of the vehicular gate. A pedestrian gate shall not be incorporated into an automated vehicular gate panel.
3. The gate must be installed in a location so that enough clearance is supplied between the gate and adjacent structures when opening and closing to reduce the risk of entrapment. Swinging gates shall not open in to the public access areas.
4. The gate must be properly installed and work freely in both directions prior to the installation of the gate operator. Do not over-tighten the operator clutch or pressure relief valve to compensate for a damaged gate.
5. The gate operator controls must be placed so that the user has full view of the gate area when the gate is moving **AND AWAY FROM THE GATE PATH PERIMETER.**

# IMPORTANT SAFETY INFORMATION

**⚠ WARNING! Not Following these instructions may cause severe injury or death.**

## IMPORTANT SAFETY INSTRUCTIONS (Continued)

6. Controls intended for user activation must be located at least six feet (6') away from any moving part of the gate and where the user is prevented from reaching over, under, around or through the gate to operate the controls. *Exception:* Emergency access controls only accessible by authorized personnel (i.e. fire, police, EMS) may be placed at any location in the line-of-sight of the gate.
7. The Stop and/or Reset button must be located in the line-of-sight of the gate. Activation of the reset control shall not cause the operator to start.
8. A minimum of two (2) WARNING SIGNS shall be installed, in the area of the gate. Each placard is to be visible by persons located on the side of the gate on which the placard is installed.
9. **For gate operators using non-contact sensors (photoelectric beam or like) in accordance with section 32.1.1 of the UL standard:**
  - a. See instructions on the placement of non-contact sensors for each type of application (refer to page 6).
  - b. Care shall be exercised to reduce the risk of nuisance tripping, such as when a vehicle, trips the sensor while the gate is still moving, and
  - c. One or more non-contact sensors shall be located where the risk of entrapment or obstruction exists, such as the perimeter reachable by a moving gate or barrier (refer to page 6).
  - d. For UL compliance: Use Only - Omron: E3K-R10K4-NR-1 // EMX: IRB-RET, IRB-MON // Miller Edge: RG-K-R, PG-K-R100, PG-K-R50, MIM-62  
For ETL compliance: The following can also be used - Viking: FA-XP30-10K // Seco-Larm E-931-33PRGQ, E-936-S45RRGQ, E-931-S50RRGQ, E-960-D90GQ // EMX NIR-50-325
10. **For a gate operator utilizing a contact sensor (edge sensor or like) in accordance with section 32.1.1 of the UL 325 standard:**
  - a. One or more contact sensors shall be located where the risk of entrapment or obstruction exists, such as a the leading edge, trailing edge, and post mounted both inside and outside of a vehicular horizontal slide gate (refer to page 6).
  - b. One or more contact sensors shall be located at the bottom of a vehicular vertical lift gate.
  - c. One or more contact sensors shall be located at the pinch point of a vehicular vertical pivot gate.
  - d. A hardwired contact sensor shall be located and its wiring arranged so that the communication between the sensor and the gate operator is not subject to mechanical damage.
  - e. A wireless contact sensor such as one that transmits radio frequency (RF) signals to the gate operator for entrapment protection functions shall be located where the transmission of the signals are not obstructed or impeded by building structures, natural landscaping or similar obstructions. A wireless contact sensor shall function under the intended end-use conditions.
  - f. One or more contact sensors shall be located on the inside and outside leading edge of a swing gate. Additionally, if the bottom edge of a swing gate is greater than 4 inches (101.6 mm) but less than 16 inches (406 mm) above the ground at any point in its arc of travel, one or more contact sensors shall be located on the bottom edge.
  - g. One or more contact sensors shall be located at the bottom edge of a vertical barrier (arm).
  - h. For UL compliance: Use only - EMX: WEL-200K // Miller Edge: ME117, ME120, ME123, MGO20, MGR20, MGS20, RB-G-K10, MIM-62  
For ETL compliance: The following can also be used - ASO: 25.30, 25.45, 95.20 // Miller Edge: ME110

# IMPORTANT SAFETY INFORMATION

 **WARNING! Not Following these instructions may cause severe injury or death.**

## MAINTENANCE

Remove the Power Harness from the Control Board. (refer to page 16)

- Clean and lubricate the gate track wheels using the recommended lubricant.
- Inspect the track for any signs of cracking or separation.
- Check that all mounting hardware of the gate operator is properly tighten.
- Ensure that the gate moves freely.
- Check for corroded parts and replace if necessary.
- Check the battery for the following:
  - Battery connections must be free of corrosion.
  - Battery voltage must be 26VDC (fully charged battery).

Reconnect the Power Harness for the Control Board. (refer to page 16)

- Check and confirm the proper operation of all safety devices (photoelectric eye, edge sensors or like).
- Check and confirm the operation of all installed accessories.
- Check and confirm the operation of all special features such as the Intelligent Obstruction Sensor, Hold Open Timer. (refer to page 22 and 24)
- Check and confirm the operation of the manual release. (refer to page 7)
- Verify the functionality of the battery backup, or power failure option, by turning off the main power source (115VAC or 230VAC). **DO NOT FORGET TO TURN ON THE MAIN POWER SOURCE AFTER VERIFICATION.**

## GENERAL SAFETY PRECAUTIONS

The following precautions are an integral and essential part of the product and must be supplied to the user. Read them carefully as they contain important indications for the safe installation, use and maintenance.

- These instruction must be kept and forwarded to all possible future users of the system.
- This product must be used only for that which it has been expressly designed.
- Any other use is to be considered improper and therefore dangerous.
- The manufacturer cannot be held responsible for possible damage caused by improper, erroneous or unreasonable use.
- Avoid operating in the proximity of the hinges or moving mechanical parts.
- Do not enter the path of the moving gate while in motion.
- Do not obstruct the motion of the gate as this may cause a situation of danger.
- Do not allow children to play or stay within the path of the moving gate.
- Keep remote control or any other control devices out of the reach of children, in order to avoid possible involuntary activation of the gate operator.
- In case of break down or malfunctioning of the product, disconnect from the main power source. Do not attempt to repair or intervene directly, contact only qualified personnel for repair.
- Failure to comply with the above may create a situation of danger.
- All cleaning, maintenance or repair work must be carried out by qualified personnel.
- In order to guarantee that the system works efficiently and correctly it is important to have the manufacturer's instructions on maintenance of the gate and operator carried out by qualified personnel.
- In particular, regular checks are recommended in order to verify that the safety devices are operating correctly.

**All installation, maintenance and repair work must be documented and made available to the user.**

# IMPORTANT SAFETY INFORMATION

## **⚠ CAUTION: To Reduce the Risk of Fire or Injury to Persons:**

- a. Use only the following type and size battery(ies): Yuasa NP7-12 or VIKING DUBA12
- b. Do not dispose of the battery(ies) in fire. The cells may explode. Check with local codes for possible disposal instructions.
- c. Do not open or mutilate the battery(ies). Released electrolyte is corrosive and may cause damage to the eyes or skin. It may be toxic if swallowed.
- d. Exercise care in handling batteries in order not to short the battery with conducting materials such as rings, bracelets and keys.
- e. Change the battery(ies) provided with or identified for use with this product only in accordance with the instructions and limitations specified in this manual.
- f. Observe proper polarity orientation between the battery(ies) and charging circuit.
- g. Do not mix batteries of different sizes or from different manufactures in this product (applies to products employing more than one user replaceable secondary battery).
- h. A battery-operated product employing a secondary battery supply intended to be charged within the product shall contain specific instructions concerning the proper method of charging.

## UL325 Gate Operator Classifications

### GLOSSARY

#### RESIDENTIAL VEHICULAR GATE OPERATOR

**CLASS I** - A vehicular gate operator (or system) intended for use in garages or parking areas associated with a residence of one-to four single families.

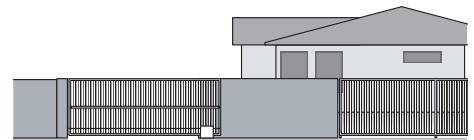

#### COMMERCIAL/GENERAL ACCESS VEHICULAR GATE OPERATOR

**CLASS II** - A vehicular gate operator (or system) intended for use in a commercial location or building such as a multi-family housing unit (five or more single family units), hotel, garages, retail store, or other building servicing the general public.

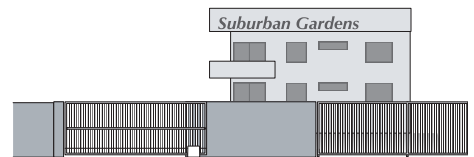

#### INDUSTRIAL/LIMITED ACCESS VEHICULAR GATE OPERATOR

**CLASS III** - A vehicular gate operator (or system) intended for use in an industrial location or building such as a factory or loading dock area or other locations not accessible by or intended to service the general public.

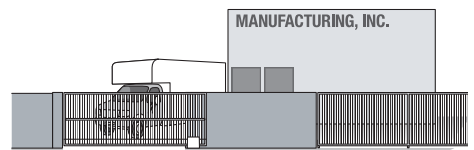

#### RESTRICTED ACCESS VEHICULAR GATE OPERATOR

**CLASS IV** - A vehicular gate operator (or system) intended for use in a guarded industrial location or building such as an airport security area or other restricted access locations not servicing the general public, in which unauthorized access is prevented via supervision by security personnel.

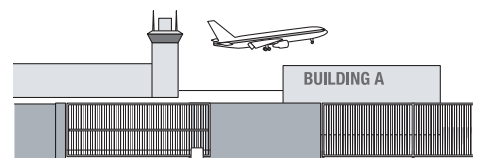

#### Install the gate operator only when:

The operator is appropriate for the construction of the gate and the Usage Class of the gate.

# IMPORTANT SAFETY INFORMATION

**⚠ WARNING! Not Following these instructions may cause severe injury or death.**

## Monitored Entrapment Protection Requirements

### IMPORTANT: MONITORED PROTECTION MUST BE INSTALLED

- **REQUIRED BY UL 325, an approved MONITORED entrapment protection sensor is REQUIRED to be installed in all areas accessible to potential entrapment and pinch points.**
- For Slide Gate Operators, a minimum of two monitored entrapment sensors are required to be connected as follows: Either one to the UL terminal and one connected to the Re-Open terminal, OR two monitored devices connected to the UL terminal, one for **EACH DIRECTION** of travel.
- **⚠** An external sensor connected to the “Re-Open” input terminal will protect against entrapment **ONLY** in the closing direction.
- The installed sensor **MUST** be “**10K Resistor Based**”.
- You may connect up to **FOUR** monitored sensors, wired in parallel, to either the “UL” and/or “Re-Open” terminals, for a total of 8 monitored sensors.
- **Failure to install the required monitored entrapment protection sensor(s) may render the gate operator INOPERABLE. The gate can be moved manually. Refer to page 7.**
- Consult the installation manual of the sensor for detailed information about the usage, installation and maintenance.
- Use only UL Recognized Component Edge Sensors and Photoelectric Sensors. Refer to pg 3.

**SLIDE GATE ENTRAPMENT ZONE** – Locations between a moving gate and a counter opposing edge or surface where entrapment is possible up to 1.8 m (6 ft) above grade. Such locations occur if during any point in travel the gap between a moving gate and fixed counter opposing edges or surfaces is less than 406 mm (16 in).

### Photoelectric Sensor (non-contact sensor)

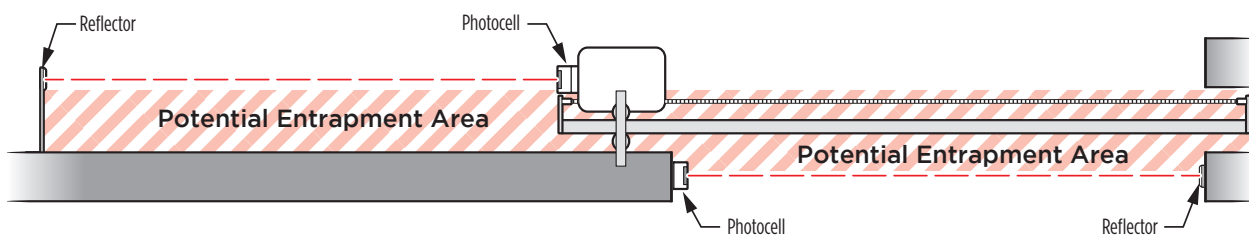

### Edge Sensor (contact sensor)

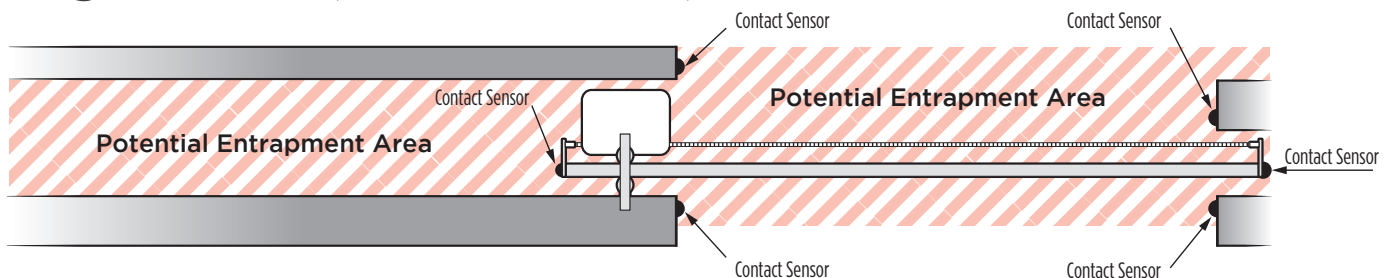



# IMPORTANT SAFETY INFORMATION

**⚠ WARNING! Not Following these instructions may cause severe injury or death.**

## Monitored Entrapment Protection Installation

**⚠ IMPORTANT:** A minimum of two Monitored External Entrapment Sensors are required to be connected as follows: One to the UL terminal and one connected to the Re-Open terminal, OR two sensors connected to the UL terminal, one for **EACH DIRECTION** of travel.

**“UL”** Protects against entrapment in both the opening and closing directions. Input will reverse the gate momentarily in the opposite direction it was traveling. Refer to page 18.

**“Re-Open”** Protects against entrapment in the closing direction ONLY. Input will reverse the gate all the way to the Open Limit. Refer to page 18.

**STEP 1:** Connect the monitored entrapment protection sensor(s) to the Viking Control Board.

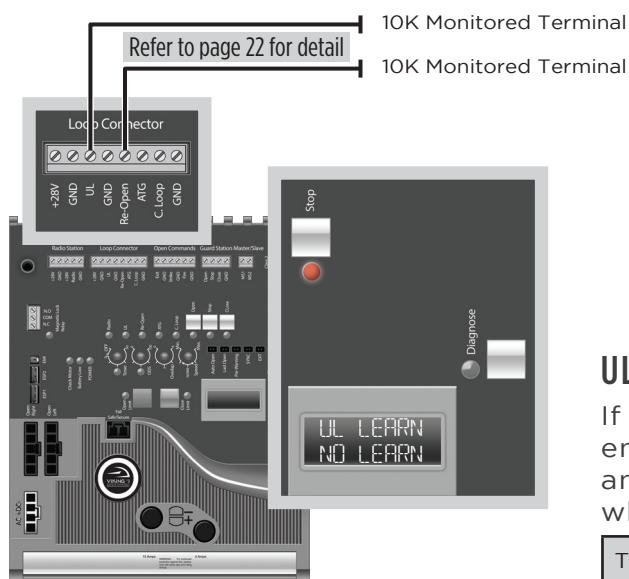

**STEP 2:**

**Execute the Learn Process:**

- Press and release the “Diagnose” button until you see UL LEARN NO LEARN on the LCD Display.
- Press and hold the “Stop” button.
- Toggle the “Diagnose” button once.
- The number of Monitored sensors connected to the “UL” or “Re-Open” terminals will now be displayed.

EXAMPLE: UL LEARN  
                  UL2 RO1

### UL SENSOR ERRORS:

If a problem occurs with one of the monitored entrapment sensors, the “Stop” LED will illuminate and an ERR message will be displayed, indicating which input terminal(s) the sensor is connected to.

TERMINAL:	“UL”	“Re-Open”	“UL” & “Re-Open”
ERROR MESSAGE:	ERR SENS UL	ERR SENS RO	ERR SENS UL RO

## Manual Release

When manual operation is required:

1. Lift the Access Door, located on the front of the cover.
2. Press the Manual Release Switch to the “RELEASE” Position.

**The gate can now be moved manually.**  
**To resume normal operation, press the switch to the “ENGAGE” position.**

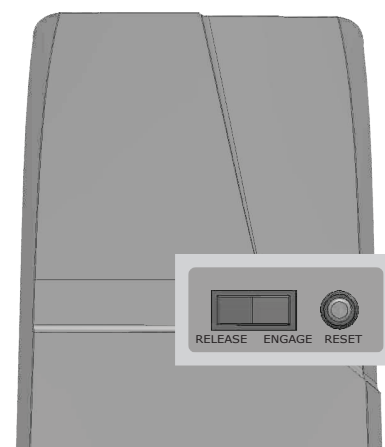

# IMPORTANT SAFETY INFORMATION

**⚠ WARNING! Not Following these instructions may cause severe injury or death.**

## Audible Alarm Reset Switch Installation

### Manual Reset for the Audible Alarm

- UL325 standard requires an audible alarm to sound after two consecutive events detected by the inherent entrapment protection of the gate operator (obstruction sensor).
- The audible alarm will continue to sound for 5 minutes or until a stop command is actuated.
- The Stop command can be actuated in three different forms:
  1. Using the Built in Stop switch on the Control Board or;
  2. Using an External Stop button within the sight of the gate, away from moving parts of the gate and out of reach of children.
    - a. Controls intended for user activation must be located at least six feet (6') away from any moving part of the gate and where the user is prevented from reaching over, under, around or through the gate to operate the controls. Outdoor or easily accessible controls shall have a security feature to prevent unauthorized use.
    - b. The Stop and/or Reset button must be located in the line-of-sight of the gate. Activation of the reset control shall not cause the operator to start.
  3. Using the "Alarm Reset" Button on the operator that is externally accessible from the covers Access Door.

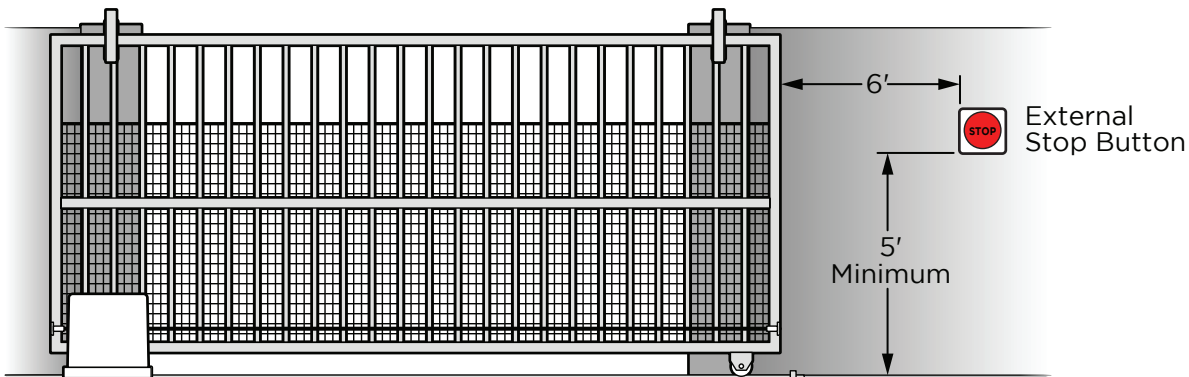
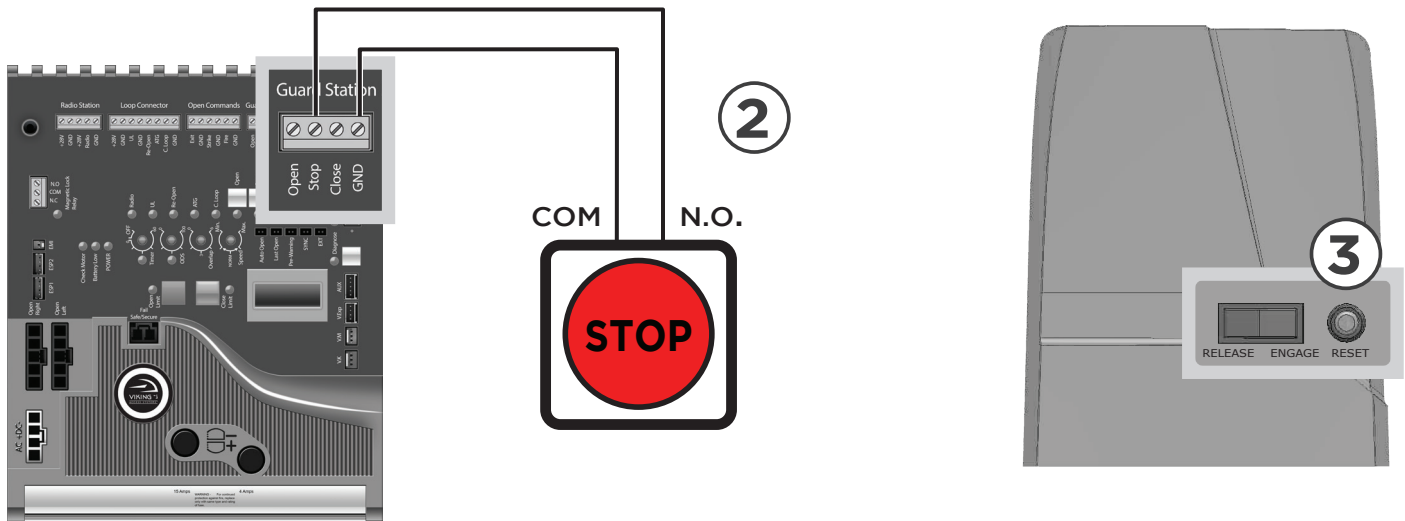

# IMPORTANT SAFETY INFORMATION

 **WARNING!** Not Following these instructions may cause severe injury or death.

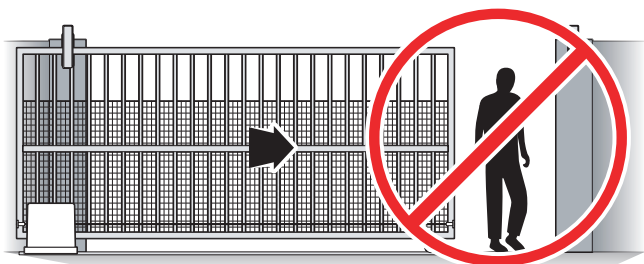

**DO NOT** allow pedestrian use of this gate

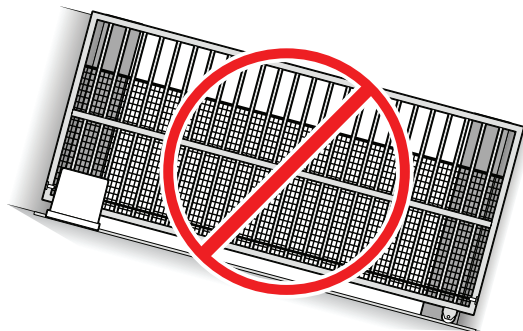

**DO NOT** install the gate operator to lift gates

## Locate Control Buttons

- Within sight of the gate,
- At a minimum height of 5 feet so small children are not able to reach it; and
- At least 6 feet away from all moving parts of the gate.

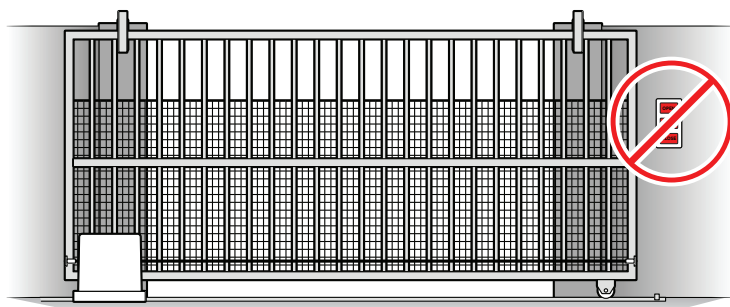

## Warning Placard Installation

- All Warning Placards must be installed where visible in the area of the gate.
- A minimum of two placards shall be installed.
- A placard is to be installed in the area of each side of the gate and be visible.

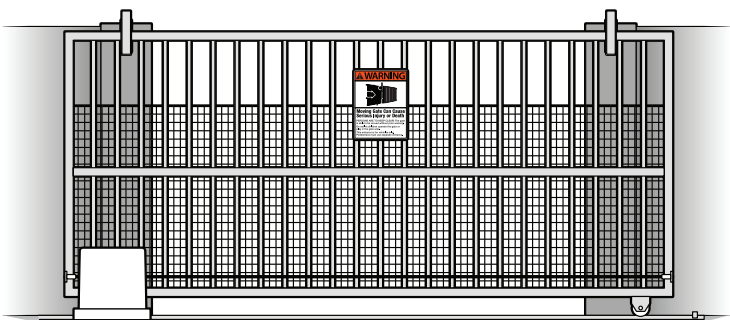

# SPECIFICATIONS

## SPECIFICATIONS

Max Gate Length	75 Feet	Main Power Frequency	50Hz / 60Hz
Max Gate Weight	2200 lbs	Main Power Fuse	4.0A Timed
UL 325 Classification	Class I, II, III, IV *refer to page 5	Alternative Power	24VAC/VDC (60VA) or Solar
Duty Cycle	100%	Accessory Power	24VDC (750mA)
Operating Voltage	24VDC	Power Consumption	75mA
Main Power Source	120VAC / 240VAC Single Phase	Motor Current Draw - Typical	7.0A
Main Power Current	3.0A / 1.5A	Operating Temperature	-20°F (-28°C) to 160°F (71°C)

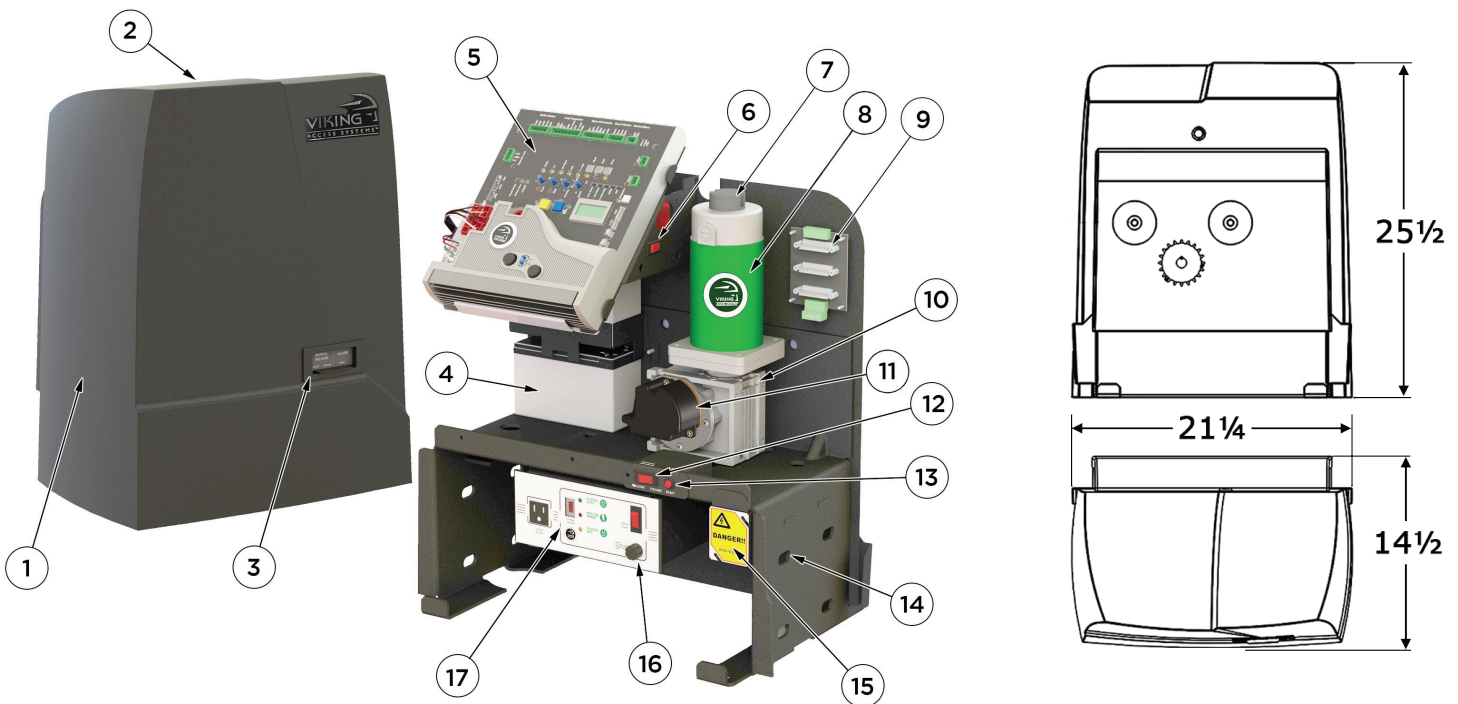

1. OPERATOR COVER
2. COVER LOCK
3. ACCESS DOOR  
external access to the Manual Release Switch and Alarm Reset Button
4. BATTERY BACKUP SYSTEM
5. VFLEX CONTROL BOARD
6. BATTERY SWITCH  
disconnects batteries from the charging circuit during troubleshooting
7. EPS (ELECTRONIC POSITIONING SENSOR)  
redundant sensor for the digital limits
8. MOTOR
9. LOOP RACK  
for convenient loop detector installation
10. GEARBOX
11. SPS (SMART POSITION SENSOR)  
main sensor for the digital limits
12. MANUAL RELEASE/MOTOR SWITCH  
discontinues power to the motor and allows for manual operation of the gate
13. ALARM RESET BUTTON  
resets the operators alarm
14. POST MOUNTING U-BOLT HOLES  
for optional post mount installation
15. J-BOX  
high voltage power supply connection
16. EMI FUSE  
main power supply protection
17. MODULAR POWER BOX  
removable; provides a convenient solution for optional low voltage installations

# CONTROL BOARD REFERENCES

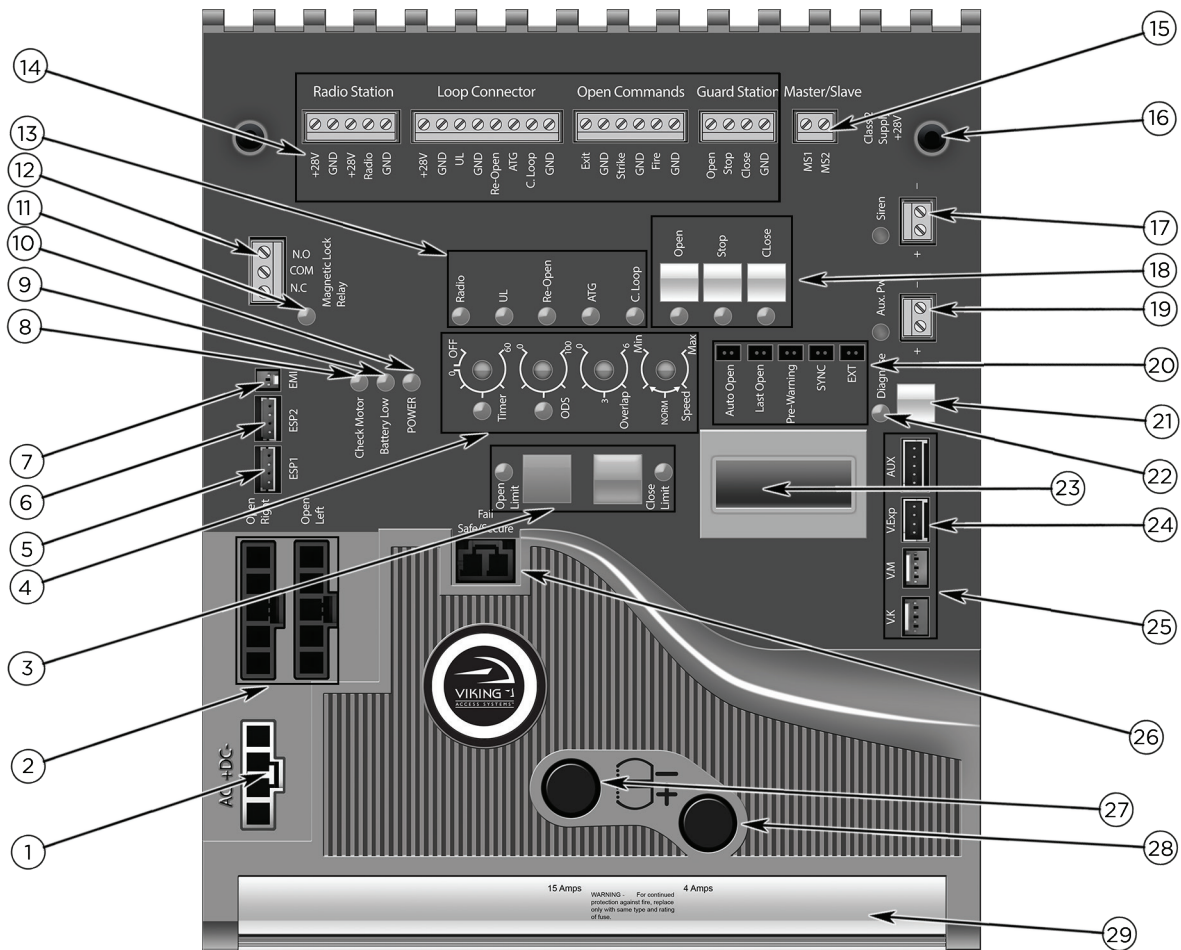

1. POWER HARNESS CONNECTOR provides power to the Control Board. pg 16-17
2. "OPEN LEFT" & "OPEN RIGHT" provides power to the motor. pg 19
3. LIMIT SETUP BUTTONS sets limit positions. pg 19
4. FEATURE ACTIVATION TRIM POTS activate and set features. pg 22
5. "EPS1" CONNECTOR available for future developments
6. "EPS2" CONNECTOR Electronic Positioning Sensor redundant limit monitoring
7. EMI BOARD CONNECTOR monitors the high voltage power supply.
8. "CHECK MOTOR" Status LED indicates motor power status. pg 34
9. "BATTERY LOW" Status LED indicates battery power status. pg 34
10. "POWER" Status LED Control Board power status. pg 16,34
11. "MAGNETIC LOCK RELAY" Status LED status of this on-board relay. pg 32, 34
12. "MAGNETIC LOCK RELAY" Terminal Block connect electric locks here. pg 32, 34
13. INPUT STATUS LEDs indicates input status. pg 34-35
14. ACCESS CONTROL TERMINAL BLOCKS accessory connections. pg 26-33
15. "PRIMARY/SECONDARY" Terminal Block wired Primary/Secondary. pg 20
16. CONTROL BOARD MOUNTING HOLES secures and grounds the Control Board.
17. "Siren" Terminal Block Vikings UL Siren is connected here.
18. ON-BOARD 3 BUTTON STATION controls the gate during set up.
19. "AUX. PWR" Terminal Block used for solar applications & in-motion warning devices. pg 17, 23
20. FEATURE ACTIVATION PIN HEADERS activate features by placing a jumper onto the pin headers. pg 23
21. "DIAGNOSE" Button allows you to navigate through the Diagnostics LCD Display. pg 36-39
22. "DIAGNOSE" LED informs that errors have been detected and available on LCD Display. pg 36-39
23. LCD DIAGNOSTICS DISPLAY provides error messages, diagnostics and operator status information. pg 36-39
24. "V.EXP" CONNECTOR Smart Position Sensor connection main limit monitoring.
25. EXPANSION PRODUCT CONNECTIONS connections for additional products from Viking Access Systems. pg 21, 44
26. "FAIL SAFE/SECURE" Jumper power failure option. pg 23
27. FUSE HOLDER - 20 AMP for motor circuit.
28. FUSE HOLDER - 4 AMP for charging circuit.
29. HEAT SINK secures the Control Board and dissipates heat.

# GATE OPERATOR INSTALLATION

## Concrete Pad Option

1. Follow the local building code to determine the required depth of the concrete pad.
2. Pad measurements recommended by Viking Access Systems are at least 24" long, 18" wide and 24" deep to ensure the stable operation of the operator, and a minimum of 4" above level grade to avoid any flooding of the machinery.
3. Provide a sufficient number of conduit pathways for all low power accessories such as loop detector leads, maglock, non-contact sensors, contact sensors, safety and other commands. Also provide conduit for the power supply to the operator.

⚠ DO NOT run low voltage and high voltage wiring in the same conduit.

⚠ Provide at least 12" separation between low and high voltage conduits.

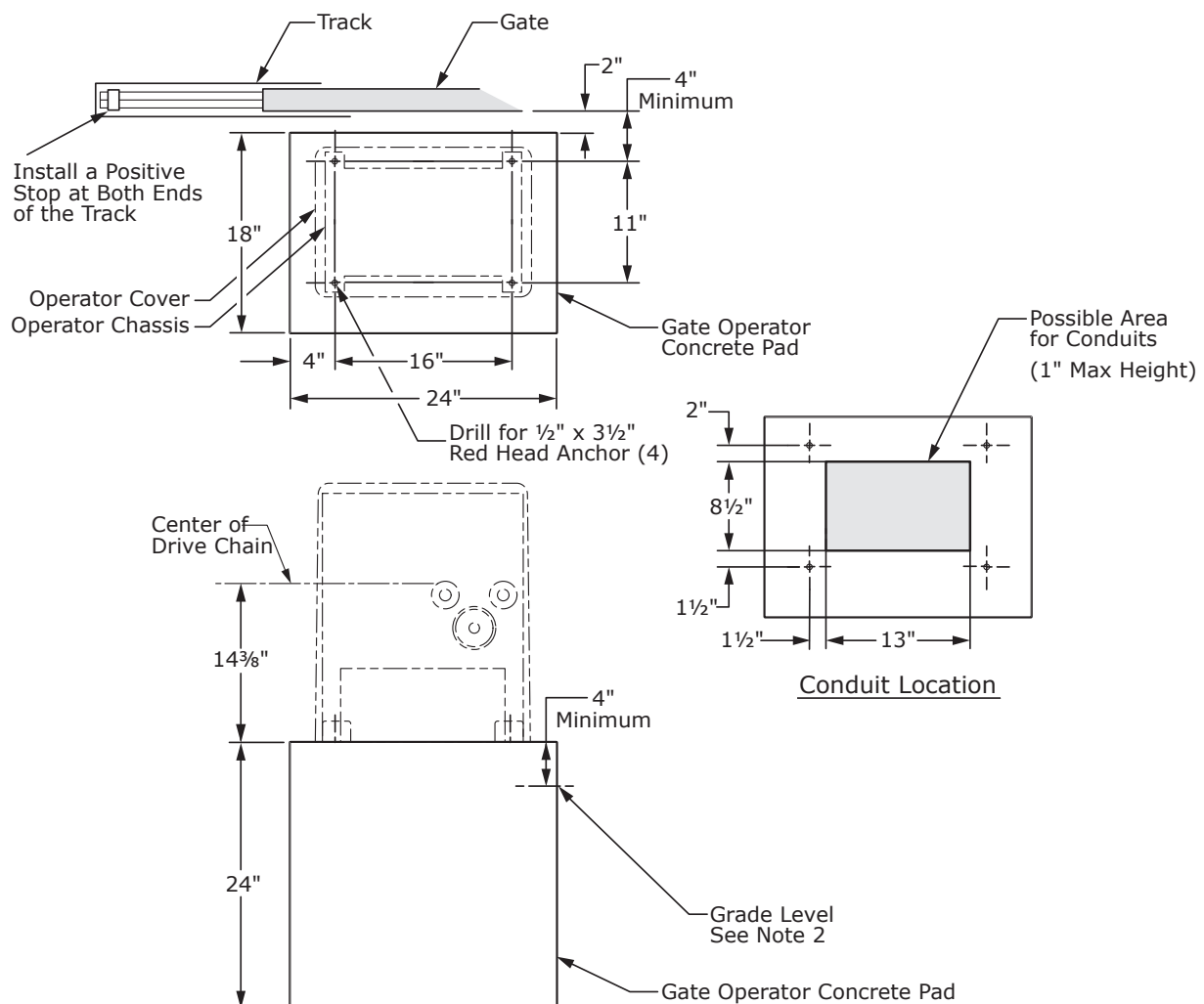

# GATE OPERATOR INSTALLATION

## Post Mounting Option

**TIP:** The operator is equipped for post mount applications and is **ready for installation**. You will only need to supply the posts and U-Bolts.

1. Consult the local building codes for the depth and concrete requirements.
2. Maximum 3.00" OD pipe.
3. Provide a sufficient number of conduit pathways for all low power accessories such as loop detector leads, maglock, non-contact sensors, contact sensors, safety and other commands. Also provide conduit for the power supply to the operator.

⚠ DO NOT run low voltage and high voltage wiring in the same conduit.

⚠ Provide at least 12" separation between low and high voltage conduits.

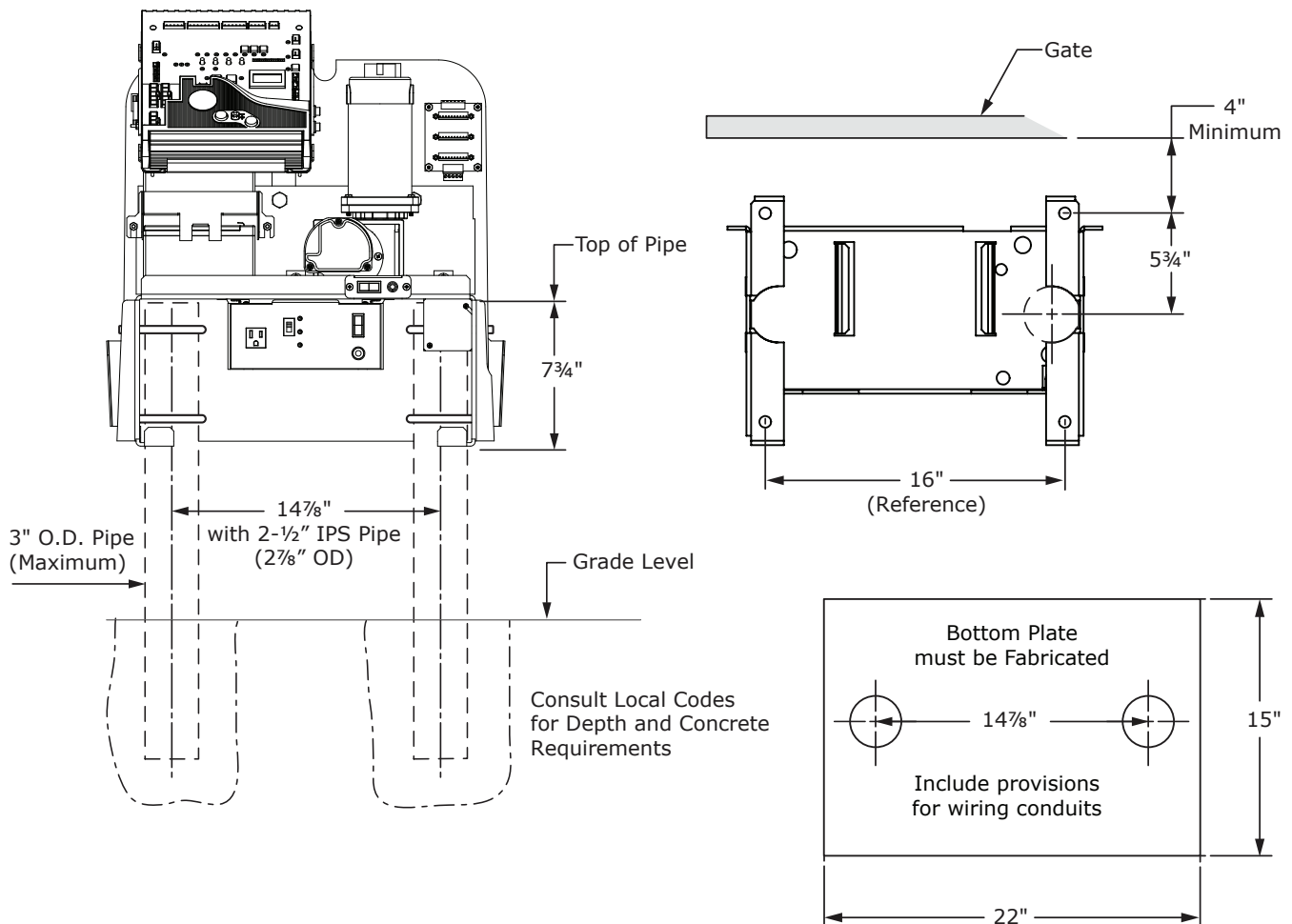

# GATE OPERATOR INSTALLATION

## Operator Positioning

**⚠ IMPORTANT:** All openings of a horizontal slide gate are guarded or screened from the bottom of the gate to a minimum of 6 feet (1.83 m) above the ground to prevent a 2-1/4 inch (57.2 mm) diameter sphere from passing through the openings anywhere in the gate, and in that portion of the adjacent fence that the gate covers in the open position.

### Plans for Front Installation

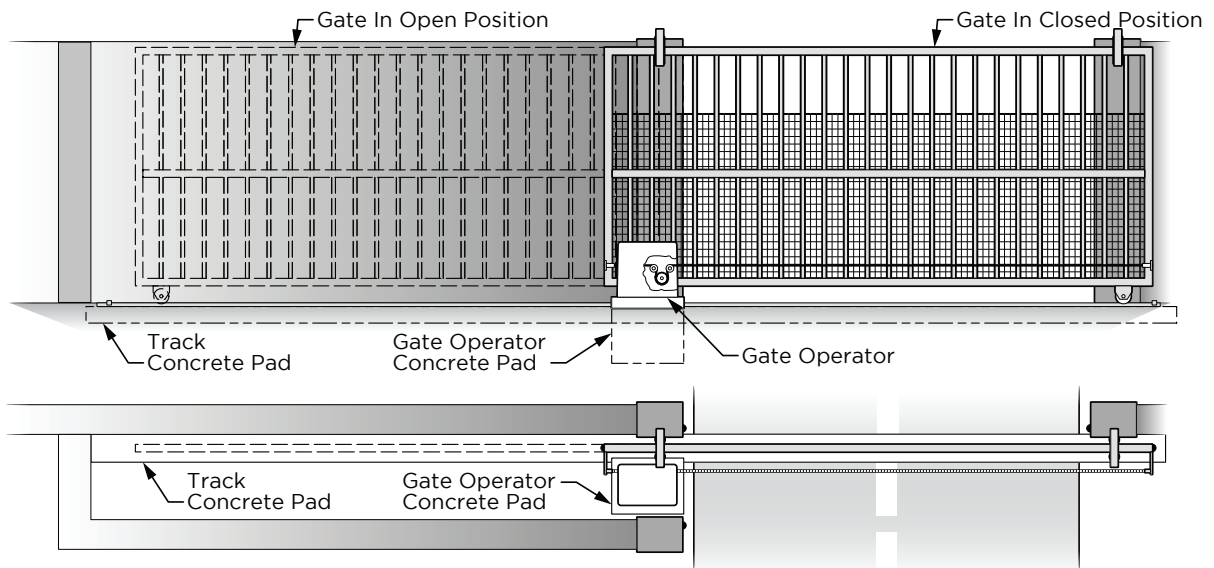

### Plans for Rear Installation

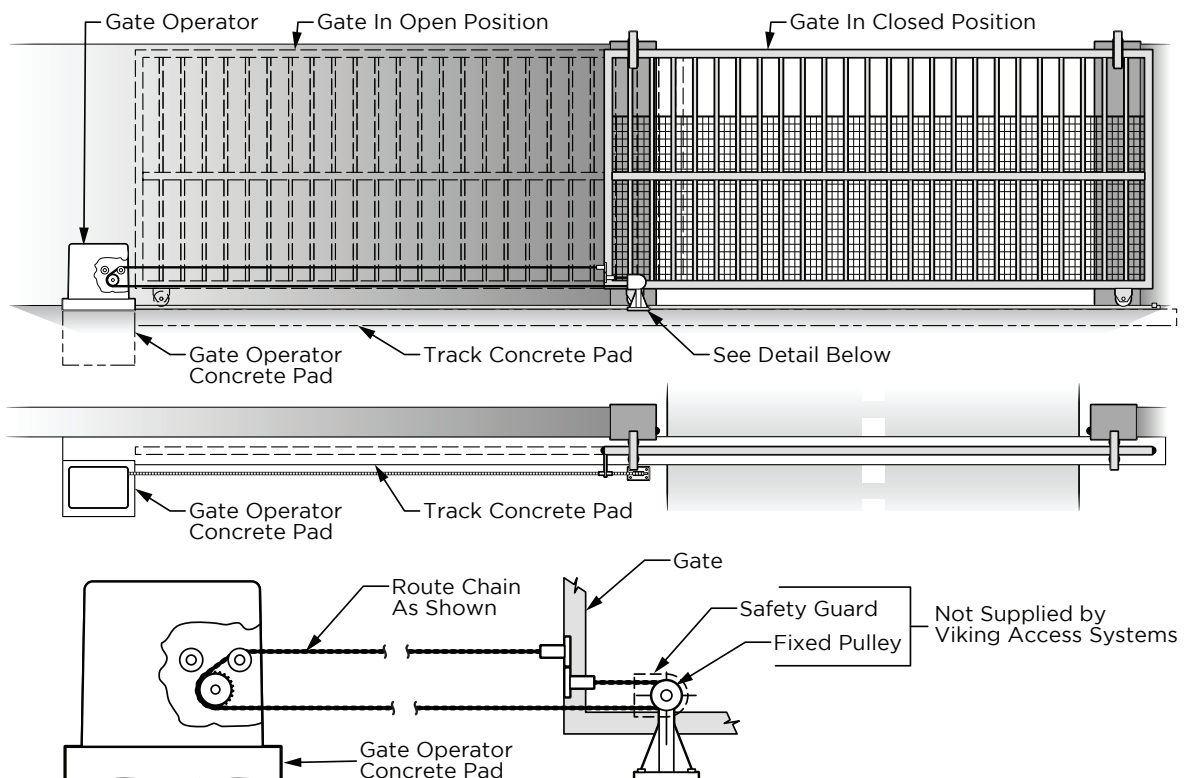



# GATE OPERATOR INSTALLATION

**⚠ TECHNICAL TIP:** Before completing the installation procedure;

- Open and close the gate manually, making sure there is sufficient space between the gate and adjacent walls.
- Check that the wheels are turning freely on the track and there are no restrictions while pushing the gate to the open and closed positions.
- Confirm that there is adequate spacing for the guide rollers and that there are no restrictions throughout the travel of the gate.

## STEP 1

Before securing the chassis to the concrete pad or posts, make sure the gate and operator are **LEVEL** and **PARALLEL**.

Minimum distance between the center of the chain and the inside edge of the gate frame is 4".

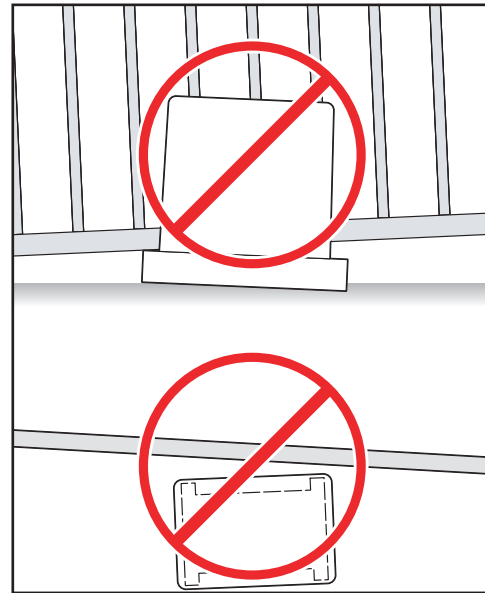
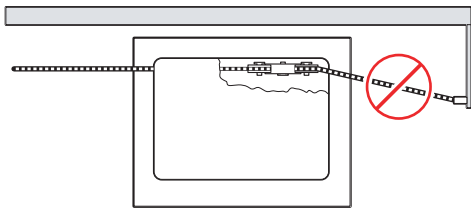
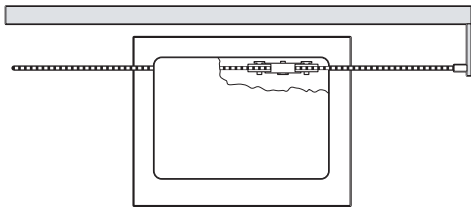

## STEP 2

**Chain Installation:** Before welding the provided chain brackets, make sure the chain will be in a straight line with, and at the same height as, the chain leaving the gate operator rollers.

## STEP 3

**Chain Tension:** The chain tension has a direct effect on the motor current draw, or work that the motor is performing. Adjust the Chain to provide 6"-8" of slack measured from the imaginary taut line, straight down to the lowest point of the chain as illustrated below.

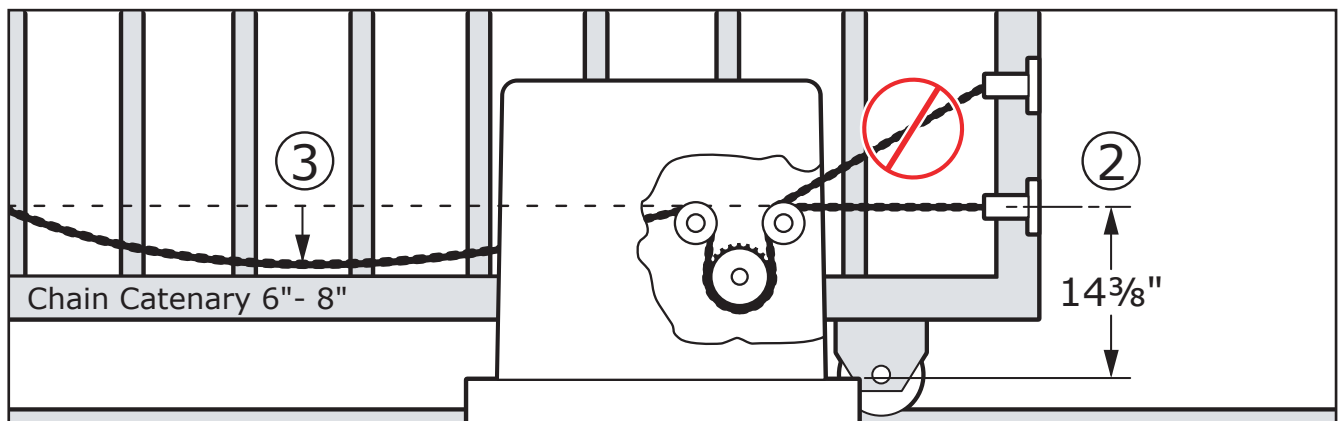

# ELECTRICAL INSTALLATION

## High Voltage Supply Option

**⚠ Caution:** Always turn off power breakers when working with high voltage. DO NOT connect the “Power Harness” to the Control Board until the electrical installation is complete and ready for verification.

### STEP 1

#### At the “Power Box”:

- Set the “Voltage Selector” according to the supply voltage (115V or 230V).
- Turn the “AC Power” switch ON

### STEP 2

**⚠ WARNING: SINGLE PHASE AC ONLY**

#### At the “J-Box”:

- Connect the incoming power wires, matching the wire color codes.
- If the supply voltage is 120VAC, connect the red wire, labeled “Outlet Power”, to the neutral (white) wires.

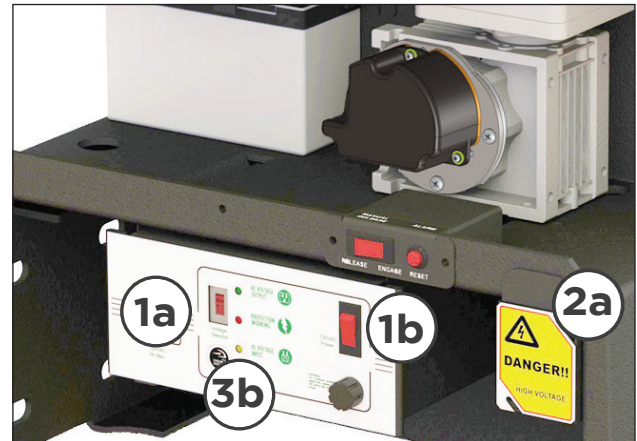

### STEP 3

- Turn ON the main facility breaker
- Verify that all three (3) LEDs are illuminated at the “Power Box”.
- Turn the “Battery Switch” ON.

#### At the Control Board:

- Connect the Power Harness and verify the “POWER” LED is illuminated solid.



**⚠ TECHNICAL TIP:** If the “Power” LED is flashing or any of the 3 LEDs on the “Power Box” are not illuminated, refer to the Troubleshooting pages.

### Tips for proper ground installation:

To minimize the effects caused by lightning, follow these guidelines:

- Use a ground rod to provide a ground reference.
- Consult your city code and be aware of underground services in the site of the gate operator to prevent inconveniences.
- All ground wires must be as short and as thick as possible.
- Always use a single bonding point for grounding.
- Connect the Earth Ground and Power Ground wires together.
- Prevent unnecessary turns or loops in all ground wires.

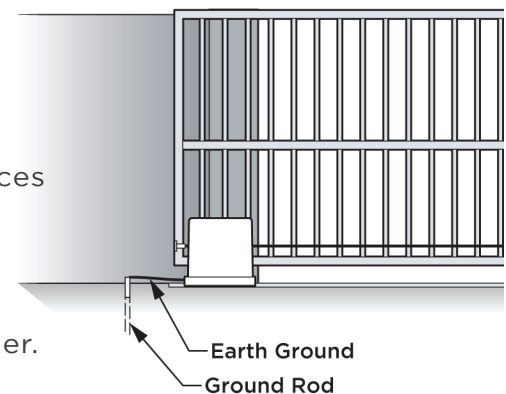

# ELECTRICAL INSTALLATION

## Low Voltage Supply Option

**TIP:** The operator is equipped with a **Modular Power Box** that can be relocated to provide power for low voltage installations. Supplies 24VAC to the operator.

**⚠ Caution:** Always turn off power breakers when working with high voltage. **DO NOT** connect the “Power Harness” to the Control Board until the electrical installation is complete and ready for verification.

Remove the “Power Box” from the operators chassis and relocate to the nearest high voltage source (115V or 230V single phase AC). Follow local codes or guidelines.

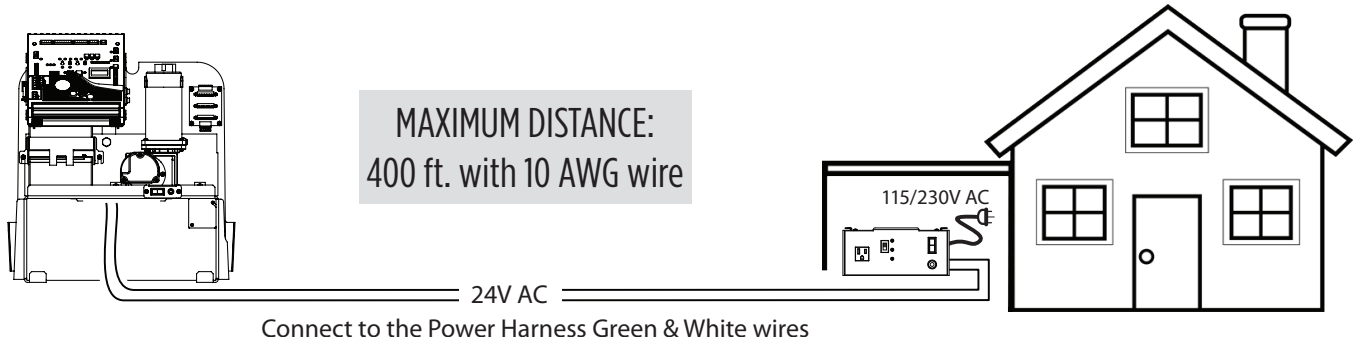

## Solar Supply Option

Vikings Solar Package (**part # VA-SOCHP**) is an efficient and effective solution to powering the operator with solar energy. (See page 44 for package details)

**⚠ Tip:** Solar efficiency can be increased by activating the “Pre-Warning” **(A)** feature. The “Aux. Pwr” **(B)** terminals will provide 24VDC to all nonessential controls, beginning 3 seconds prior to gate movement, until the gate reaches either limit. (page 23)

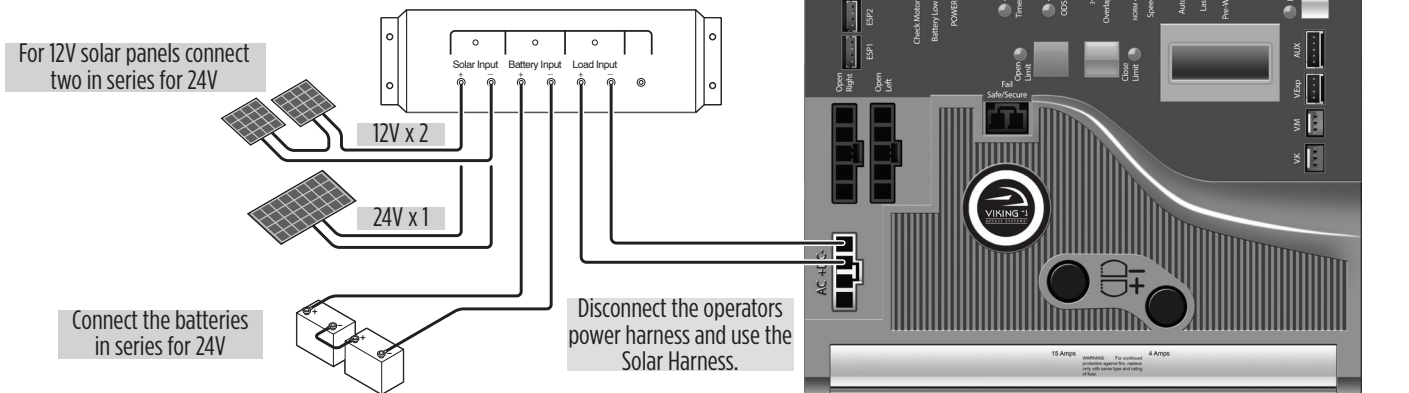

**⚠ IMPORTANT:** The number of cycles achieved daily is dependent on many factors, including local solar radiation data and power consumption of the motor and accessories. It is very important that you consider this when using solar power.

# ELECTRICAL INSTALLATION

## MONITORED UL SENSOR CONNECTIONS

### UL (Monitored Input Terminal)

The “UL” input terminal protects against entrapment in both the opening and closing directions. Input will reverse the gate momentarily in the opposite direction it was traveling when a connected device it triggered. Pages 6-7.

### Re-Open (Monitored Input Terminal)

The “Re-Open” input terminal protects against entrapment in the closing direction ONLY. Input will reverse the gate all the way to the Open Limit when a connected device it triggered. Pages 6-7.

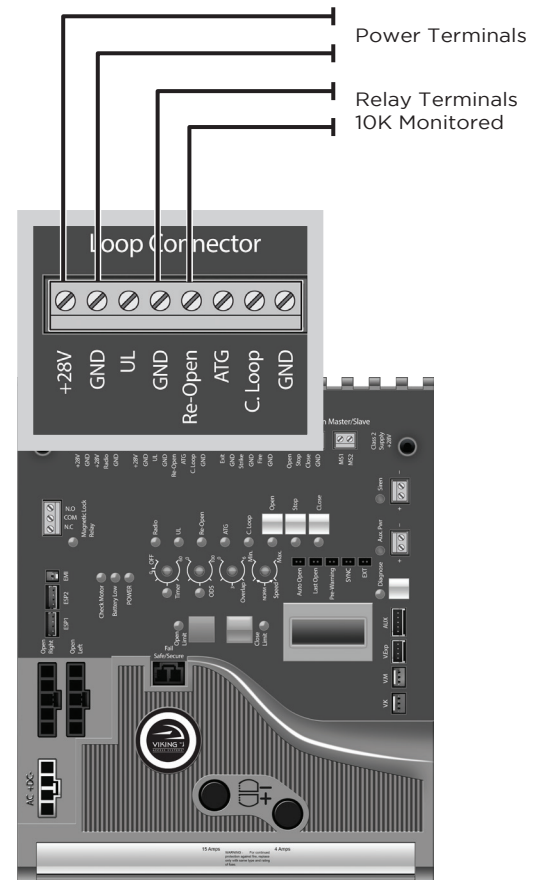
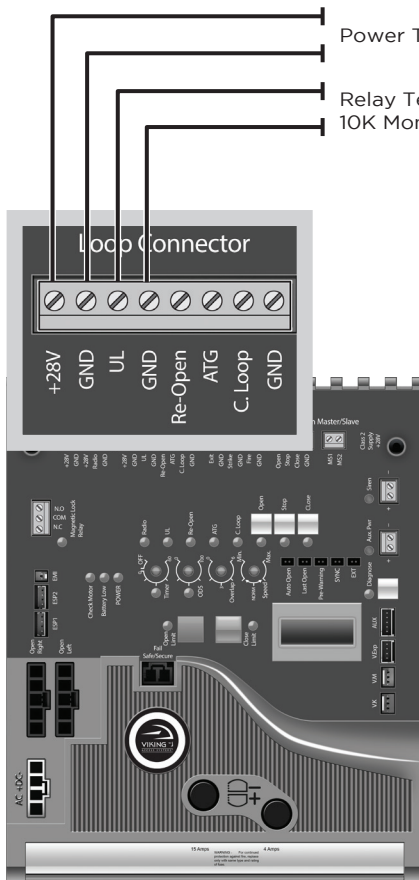

**NOTE:** The “Stop” LED will be illuminated if there is a failure with at least one monitored entrapment sensor and the gate operator will be rendered inoperable.

### Check for proper operation:

When a connected device is triggered, the “UL” LED will illuminate and, if more than one Monitored device connected, the “Stop” LED will flash rapidly to indicate an input.

⚠ If more than one Monitored device is connected to this terminal, the “UL” LED will be illuminated. This alone is inconsequential.

### Check for proper operation:

When a connected device is triggered, the “Re-Open” LED will illuminate and, if more than one Monitored device connected, the “Stop” LED will flash rapidly to indicate an input.

⚠ If more than one Monitored device is connected to this terminal, the “Re-Open” LED will be illuminated. This alone is inconsequential.

⚠ **TECHNICAL TIP:** For more information regarding accessory connections to the Control Board and individual input terminal functions, refer to pages 26-27.

# LIMITS SETUP

## ⚠ NOTE:

1. The 1st cycle after the limit setup is the “Learn Cycle”. Allow at least one complete cycle to confirm your settings.
2. During the limit setup process, the operator will run at half speed.

## STEP 1

Connect the “Motor Harness” to the Control Board.

- a. “OPEN RIGHT” Connector if the gate opens to the Right, when viewed from inside.
- b. “OPEN LEFT” Connector if the gate opens to the Left, when viewed from inside.

## STEP 2

Position the gate to one of the desired limit positions then press and hold the corresponding Limit Button until the LED stops flashing and illuminates solid.

Repeat this step for the other limit position.

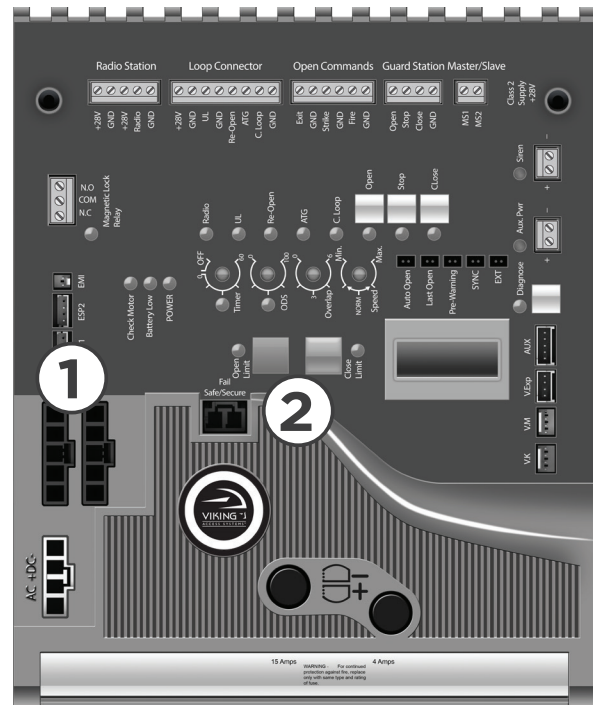

**Tip:** The gate can be moved electronically with the “Open”, “Stop” and “Close” buttons on the Control Board or manually by following the instructions on page 7.

## To Readjust Limits:

1. Clear the current limit setting by holding down the corresponding Limit Button until the LED is flashing.
2. Repeat STEP 2 above to set the limit.

LIMIT LED INDICATIONS	
OFF	Gate is not at the set limit position.
SOLID	Gate is at the set limit position.
FLASHING	Limit position is not set or has been erased.

# PRIMARY/SECONDARY SETUP

## Two Wire Communication

**⚠ IMPORTANT:** DO NOT run the Primary/Secondary communication cable in the same conduit or within 12" of 115 - 230V power supply cables.

**⚠ Technical Tip:** DO NOT set the "Timer" and/or "Overlap" features on both operators Control Boards. Only turn these features on at the Primary Control Board.

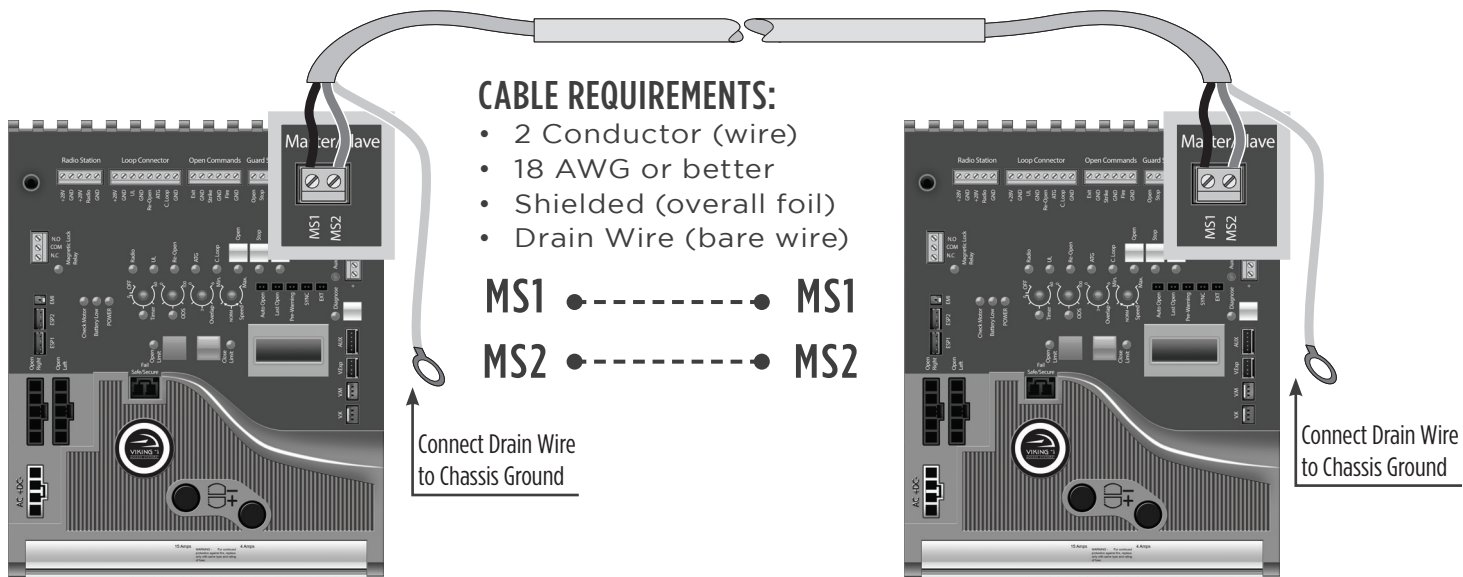

### Step 1

Connect shielded cable to "Primary/Secondary" connectors at the control boards

### Step 2

At the Primary Operator:

Connect the entrapment protection sensor(s) as described on pages 7 and 18.



### Step 3

At the Secondary Operator:

Turn ON the DUAL MODE Feature:

- Toggle the "Diagnose" button until you see DUAL MODE on the LCD Display.
- Default setting is OFF.
- Press and hold the "Stop" button.
- Toggle the "Diagnose" button once.
- The feature should now be displayed as ON.

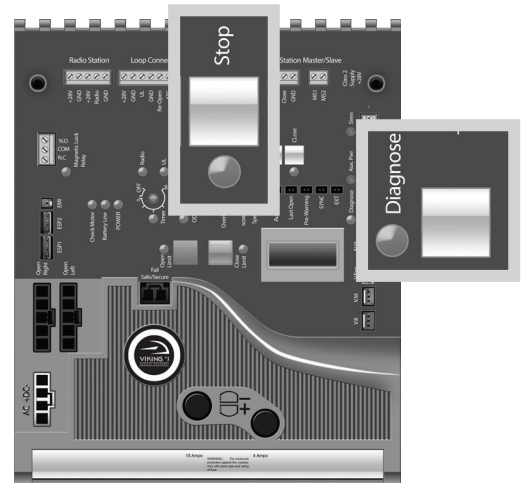

# PRIMARY/SECONDARY SETUP

## Wireless Communication Options

### REQUIRED ADD-ON:

**Viking Konnect** - Wireless Primary/Secondary Kit **PART# VA-KONNECT-MS**

⚠ **Technical Tip:** DO NOT set the “Timer” and/or “Overlap” features on both operators Control Boards. Only turn these features on at the Primary Control Board.

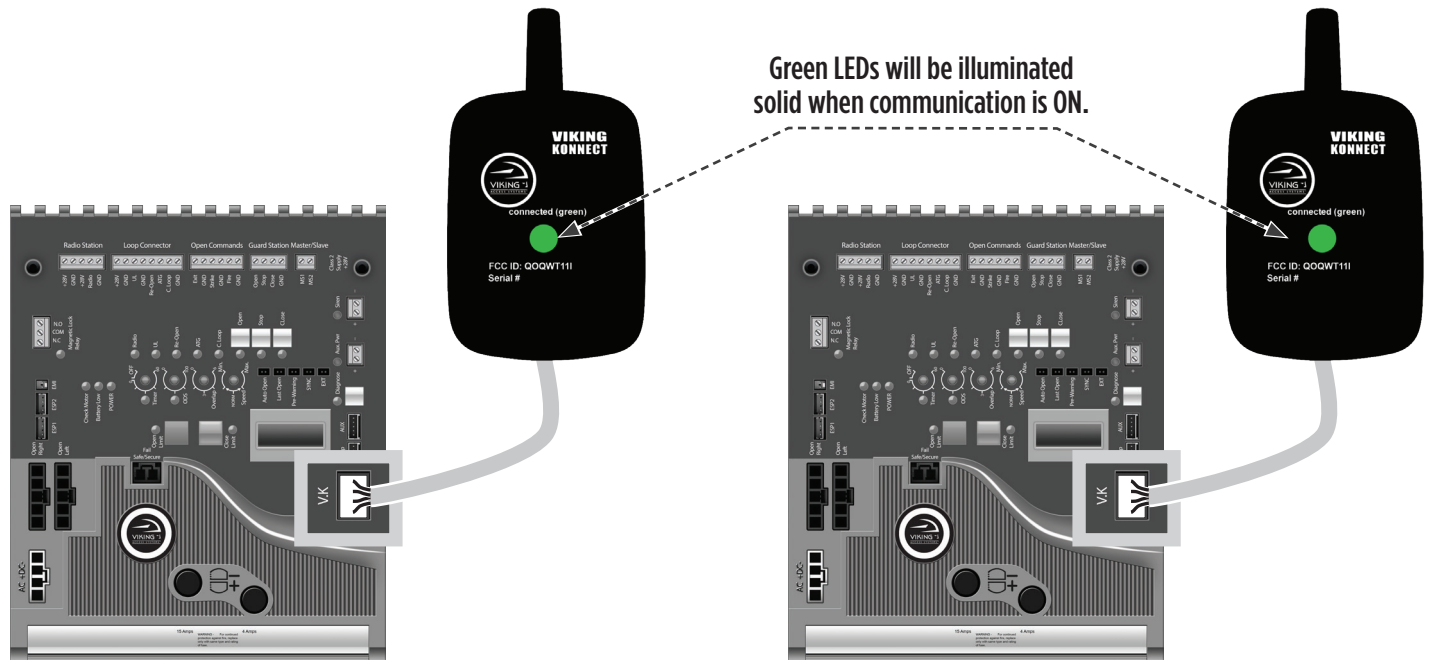

### Step 1

Plug the modules on to the “V.K” plug & play connection of each operators Control Board. It is not important which board the Primary or Secondary module is placed on.

### Step 2

#### At the Primary Operator:

**Connect the entrapment protection sensor(s)** as described on pages 7 and 18.

### Step 3

#### At the Secondary Operator:

**Turn ON the DUAL MODE Feature:**

- Toggle the “Diagnose” button until you see **DUAL MODE ON** on the LCD Display.
- Default setting is OFF.
- Press and hold the “Stop” button.
- Toggle the “Diagnose” button once.
- The feature should now be displayed as ON.

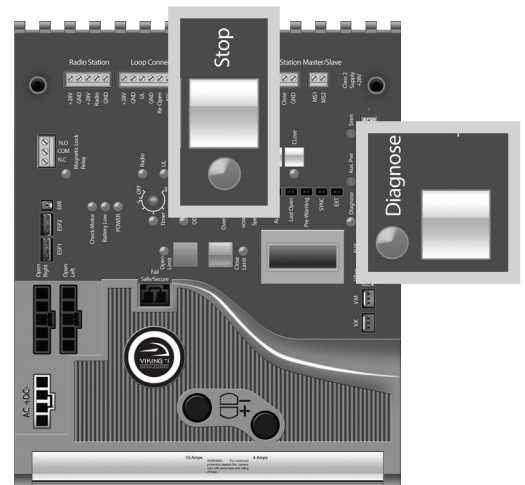

# CONTROL BOARD SETUP

## Initial Settings

### “Speed” Motor Speed

Increases or decreases the speed of gate travel.

### “ODS” Obstruction Detection Sensor

Sets the amount of force required to trip the inherent obstruction sensor.

See page 24 for more details about this feature.

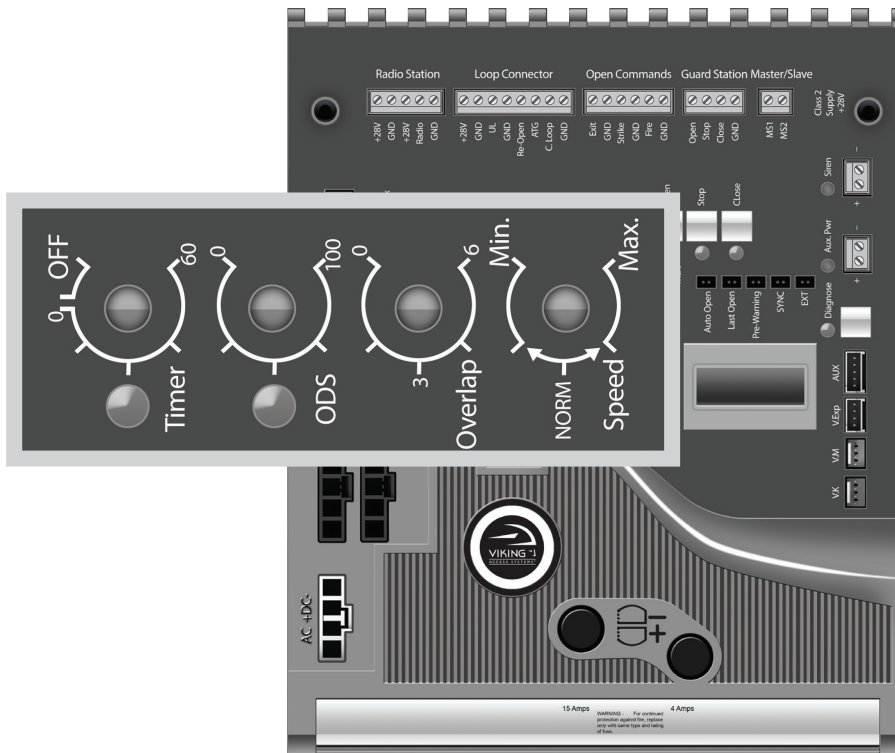

### “Overlap” Overlap Delay

⚠ This Feature is disabled on Slide Gate models.

### “Timer” Hold Open Timer

Automatically closes the gate after the selected amount of time from 1-60 seconds.

Turning the dial between “0” and “OFF” will disable this feature, requiring a close command to close the gate.



# CONTROL BOARD SETUP

## Initial Settings

**NOTE:** Installing a shunt, or jumper, on the pins will activate the feature.

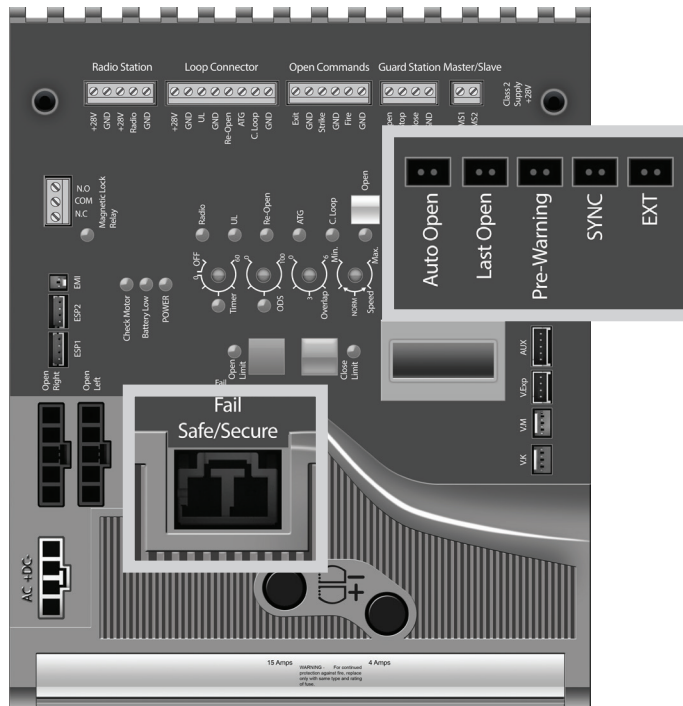

### “Auto Open” - Power Failure Option

Opens the gate automatically during power failure. Resumes normal operation when power is restored.

### “Last Open” - Power Failure Option

Opens the gate automatically when the battery backup voltage is critically low.

### “Fail Safe/Secure”

During power failure, determines the force required to manually move the gate.

#### • Fail Safe Mode:

By removing the wire-jumper plug from the “Fail Safe/Secure” connector:

The gate can move manually with a relatively low amount of force.

#### • Fail Secure Mode:

By inserting the wire-jumper plug into the “Fail Safe/Secure” connector:

The gate will require more effort to manual move.

“Pre-Warning” Initiates two options for an audible or visual warning 3 seconds prior to gate motion and will continue:

#### 1. Until gate reaches closed limit:

“Magnetic Lock” terminals provide a contact between “COM” and “N.O.”.

#### 2. Until gate reaches either limit:

“AUX. PWR” terminals provide 24VDC.

“Sync” Used only in conjunction with

Barrier Arm Operators. Activating this feature allows for synchronized operation with Barrier Arm Operators. See page 33.

“EXT” Available for future developments.

# CONTROL BOARD SETUP

## Obstruction Detection Sensor (ODS)

**⚠ IMPORTANT:** The appropriate “ODS” setting is dependant upon the gate installation and construction. Set this feature accordingly. Additional Safety equipment should be used to reduce possible risk of injury or vehicle damage.

### “ODS” Obstruction Detection Sensor

The Obstruction Sensor detects obstructions in the path of the traveling gate. The dial sets the amount of force required to activate the operators inherent obstruction detection.

Setting the dial to “0” will require the least amount of force to activate;

Setting the dial to “100” will require the maximum amount of force to activate.

**UL325 standard requires** an audible alarm to go off after two consecutive entrapment events sensed by the Inherent Entrapment Protection of the Gate Operator.

The audible alarm will sound for a period of 5 minutes or until a Stop command or the “Alarm Reset” switch has been actuated. (refer to page 8)

### When the Obstruction Sensor detects an obstruction it will:

1. Stop the gate’s movement and reverse it momentarily.
2. Bring the gate to a resting position.
3. Disable the Hold Open Timer feature until the Gate Operator receives a new command.

### If second obstruction is detected before the gate reaches either limit it will:

1. Stop the gate’s movement.
2. Disable the Gate Operator.
3. Sound the UL Alarm
4. A STOP command must be provided to disable the alarm and continue operation.

**⚠ TECHNICAL TIP:** The Status LED for the “ODS” will indicate the following when it has been triggered.

#### A. **Solid:** Obstruction.

Detected a sudden or abrupt increase in gate resistance.

#### B. **Flashing:** Overload.

Detected a more subtle, but sustained increase in gate resistance.

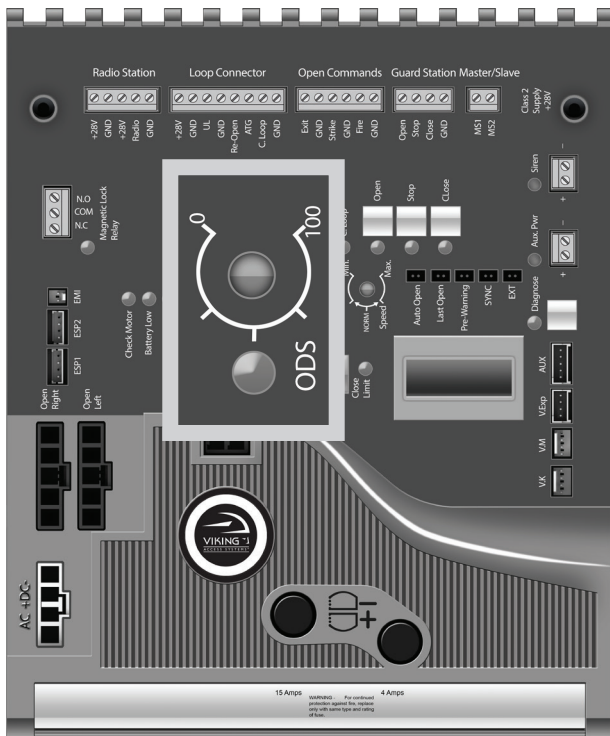

# CONTROL BOARD SETUP

## Viking Heater

The operator has an integrated heater that is thermostatically controlled. Activate this feature when the operator is used in application temperatures down to -20°F (-29°C).

### To set the heater to turn on at the Close Limit:

1. Use the “Diagnose” button to scroll through the LCD Display to “HEATER CLS”
2. Press and hold the “Stop” button on the Control Board.
3. Press and release the “Diagnose” button to turn this feature ON and OFF.



### To set the heater to turn on at the Open Limit:

1. Use the “Diagnose” button to scroll through the LCD Display to “HEATER OPN”
2. Perform steps 2-3 as described above.



**NOTE:** If the application requires the gate to be held open for any reason, set the HEATER ON for both limit positions.

**⚠ IMPORTANT:** AN EXTERNAL POSITIVE STOP **must** be used on the gate at the limit position(s) the HEATER has been set for.

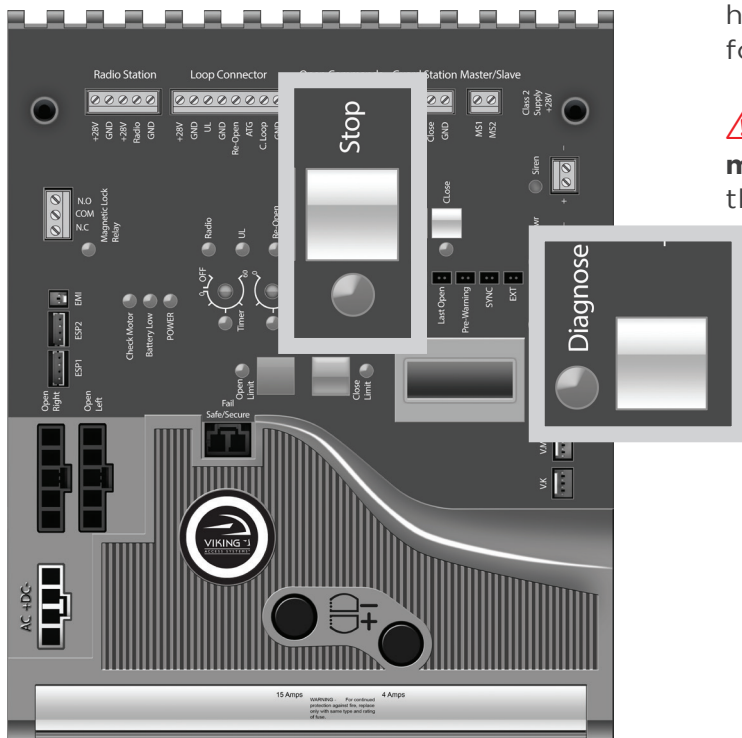

## Viking Lock Mode

Turning this feature ON will secure the gate at the closed position, preventing unauthorized manual entry. **⚠ IMPORTANT:** The EPS2 cable must be connected for this feature to function.

### Use the LCD Display to activate this feature.

1. Use the “Diagnose” button to scroll through the LCD menu to “LOCK MOD”
2. Press and hold the “Stop” button on the Control Board.
3. Press and release the “Diagnose” button to turn this feature ON and OFF.

# ACCESSORY CONNECTIONS

## Access Control Connections

### Power Connections

The Control Board provides a 24VDC output to power external devices and controls. Alternatively, for devices that require a power supply other than 24VDC, the operators Power Box contains a convenient 120VAC receptacle to connect a plug-in transformer.

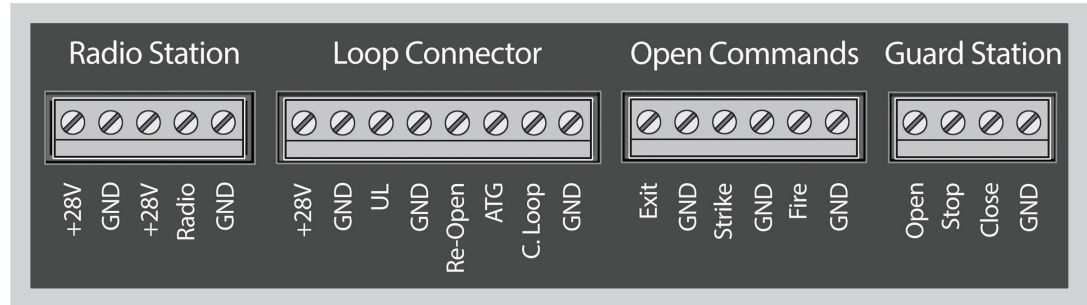

“C” = Common  
 “N.O.” = Normally Open

### Terminals Connections and Input Functions:

Viking Terminal	Function	Device Terminal
“+28V”	DC Positive	“+”
“GND”	DC Negative	“-”
“GND”	Relay Common	“C”
“Radio”		“N.O.”
	If “Timer” OFF: Open - Stop - Close	
	If “Timer” ON: Open / Reopen if closing	
“UL”	(see pages 6-7 & 18)	“N.O.”
	If stopped: Prevents the gate from moving	
	If traveling: Stops then reverses gate momentarily	
“Re-Open”	(see pages 6-7 & 18)	“N.O.”
	If stopped: No function	
	If closing: Stops then Opens gate	
“ATG” Anti-Tailgate		“N.O.”
	Input is received: Stops gate if closing	
	Input is released: Closes gate to prevent tailgating	
“C. Loop”		“N.O.”
	If not at open limit: No function	
	If at open limit: Prevents gate from Closing	
“Open”, “Exit”, “Fire” & “Strike”		“N.O.”
	If stopped: Opens gate	
	If closing: Stops then Opens gate	
“Stop”		“N.O.”
	If traveling: Stops gate	
“Close”		“N.O.”
	If stopped: Closes gate	
	If traveling: No function	

**⚠ TECHNICAL TIP:** Each input Terminal (i.e. Radio, Exit, Re-Open, UL) has a corresponding Status LED that when illuminated indicates an input is currently being provided to the terminal and the gate is responding accordingly. (See pages 34-35 LED References)

# ACCESSORY CONNECTIONS

## Relays In General

**NOTE:** Viking Access Systems does not provide the external safety devices and access controls. These items can be purchased from your dealer or distributor.

### In General

In regards to the Viking Control Board, all external safety devices and access controls contain, and are, simple relays that provide an input to the Viking Control Board when the device is activated.

When these devices are activated, their internal relays create a contact, or short, between the “C” and “N.O.” terminals. This contact is what provides the command to the Viking Control Board.

**▲ TECHNICAL TIP:** Viking uses the Normally Open “N.O.” contact from the device, excluding “fail-safe” type photo beams. In such instances, the Normally Closed “N.C.” will be used instead.

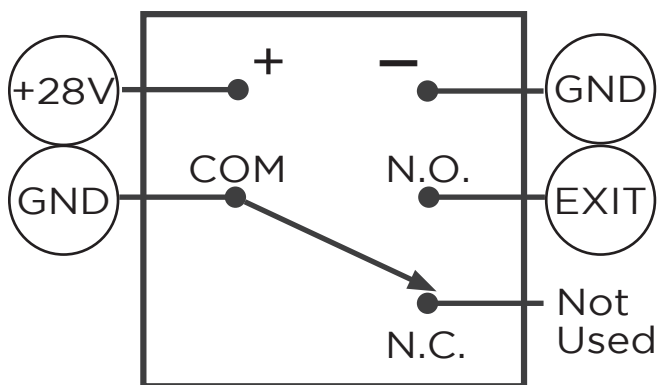

### Glossary of Terms

- 1. Terminal:** Wire Connections.
- 2. Input Terminal:** On the Viking Control Board, the terminal which is labeled for a specific command (Re-Open, Exit, Radio, etc.). The N.O. contact from the access control device is to be connected to the Input Terminal.
- 3. Terminal Block:** On the Viking Control Board, a removable block containing multiple terminals.
- 4. Relay:** The component of an access control or safety device that provides an input or command to the Viking Control Board.
- 5. “C” Relay Common Terminal:** This is the relay terminal that makes contact (a short) to the N.O. terminal when the device is activated. *Always wire this relay terminal to any “GND” terminal at the Control Board.*
- 6. “N.O.” Relay Normally Open Terminal:** The relay terminal that has an open contact to “C” while the relay is not activated, and a closed contact when the relay is activated. *Almost always wire this relay terminal to an “Input Terminal” at the Control Board,*
- 7. “N.C.” Relay Normally Closed Terminal:** The relay terminal that has a closed contact to “C” while the relay is not activated, and an open contact when the relay is activated. *This terminal is rarely used.*
- 8. Relay Coil:** Contains the terminals that provide power at the relay.
- 9. “+” Relay Positive Terminal:** The positive power pole for the relay coil. *Always wire this relay terminal to any “+28V” terminal at the Control Board.*
- 10. “-” Relay Negative Terminal:** The negative power pole for the relay coil. *Always wire this relay terminal to any “GND” terminal at the Control Board.*

# ACCESSORY CONNECTIONS

## Radio Receiver

**NOTE:** The operator may be supplied with a **FA-XR2C** Radio Receiver and (2) FA-XT4RC Transmitters.

### STEP 1

Wire the Radio Receiver as illustrated.

**⚠ TECHNICAL TIP:** The FA-XR2C Radio Receiver is IP44 rated for water resistance and can be mounted outside of the ECU Cabinet.

### STEP 2

Program the FA-XT4RC Radio Transmitters to the FA-XR2C Radio Receiver. Follow the instructions provided with the Transmitters.

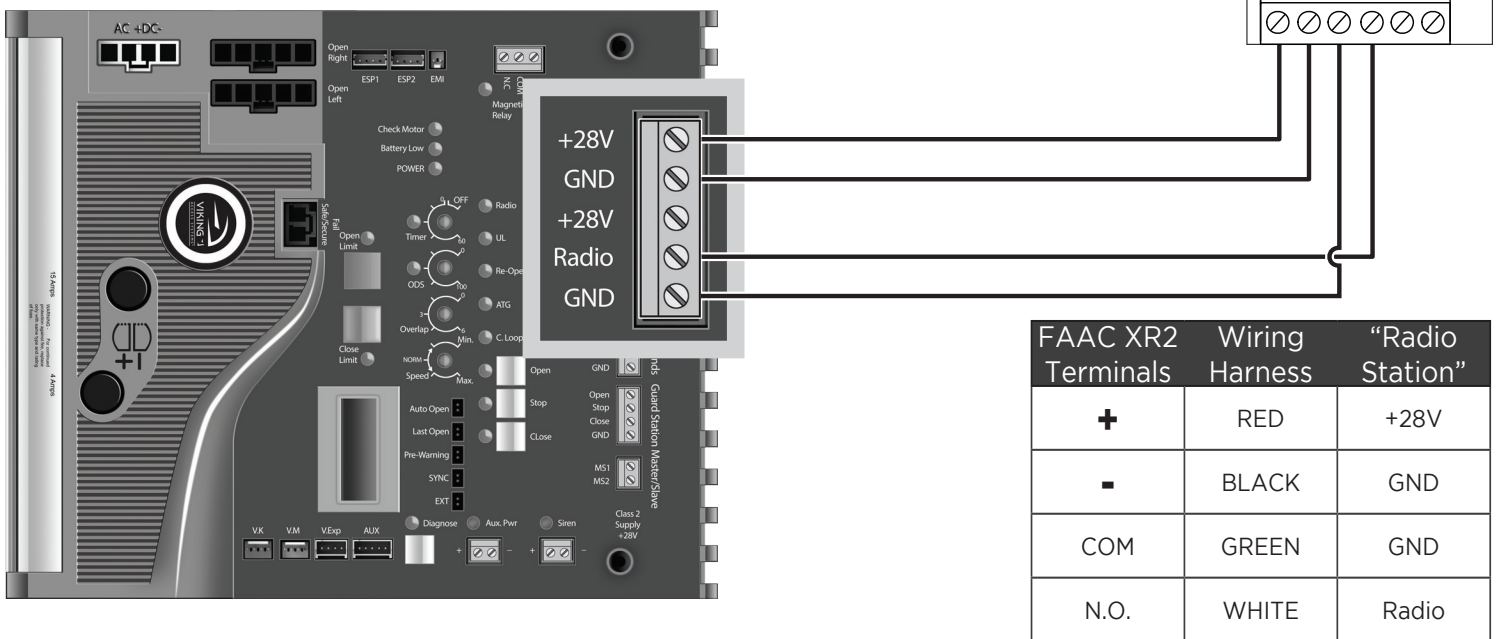

**⚠ TECHNICAL TIP:** The Control Board provides two modes of operation that a radio receiver can control the gate. For more information regarding accessory connections and terminal functions, refer to pages 26-27.

### 1. Open-Stop-Close

By having the radio receiver connected as illustrated and with the “Timer” OFF: This type of configuration is not recommended for commercial installations.

### 2. Open Only

By having the radio receiver connected as illustrated and with the “Timer” ON.

# ACCESSORY CONNECTIONS

## Photocell

**NOTE:** The operator may be equipped with a **FA-XP30-10K** Photocell. Refer to pages 6-7 for UL325 requirements.

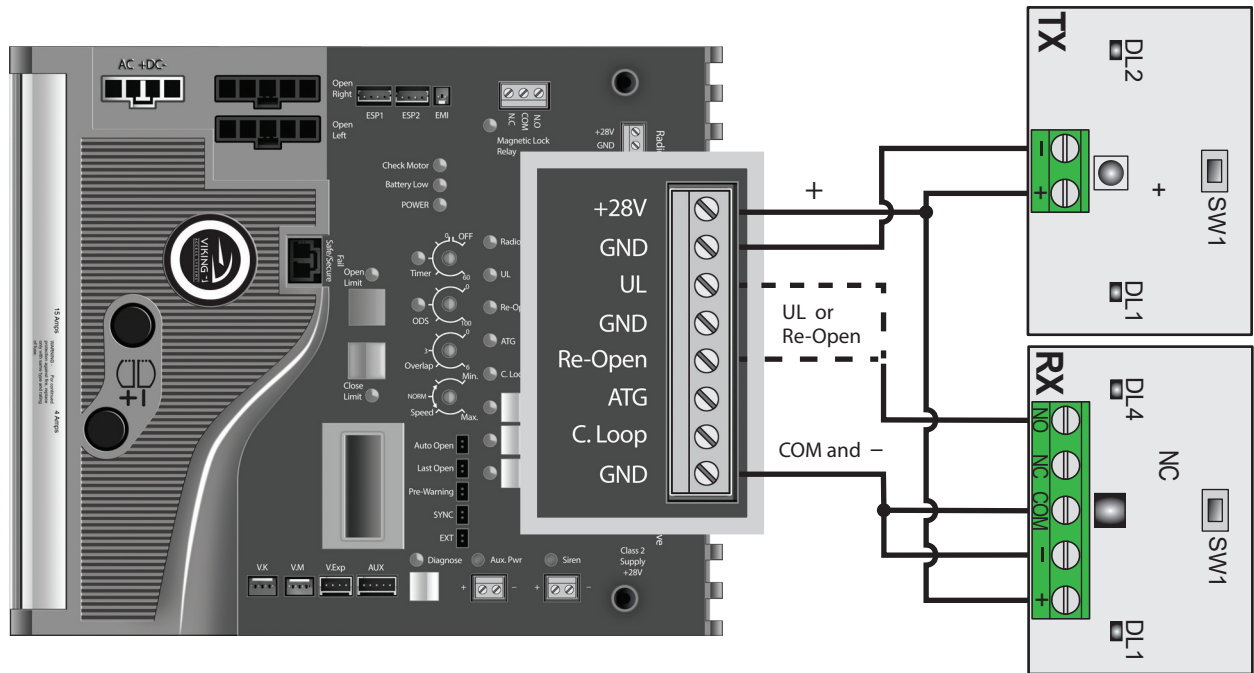

# ACCESSORY CONNECTIONS

## Viking Loop Rack

**TIP:** This operator may be equipped with a pre-wired **Loop Rack** that plug-in type loop detectors can be connected to. This provides a convenient alternative to the box type loop detectors that would need to be wired to the Control Board.

**Loop Rack: Part # VA-LR**

**Loop Rack Wiring Harness: Part # VA-LRH**

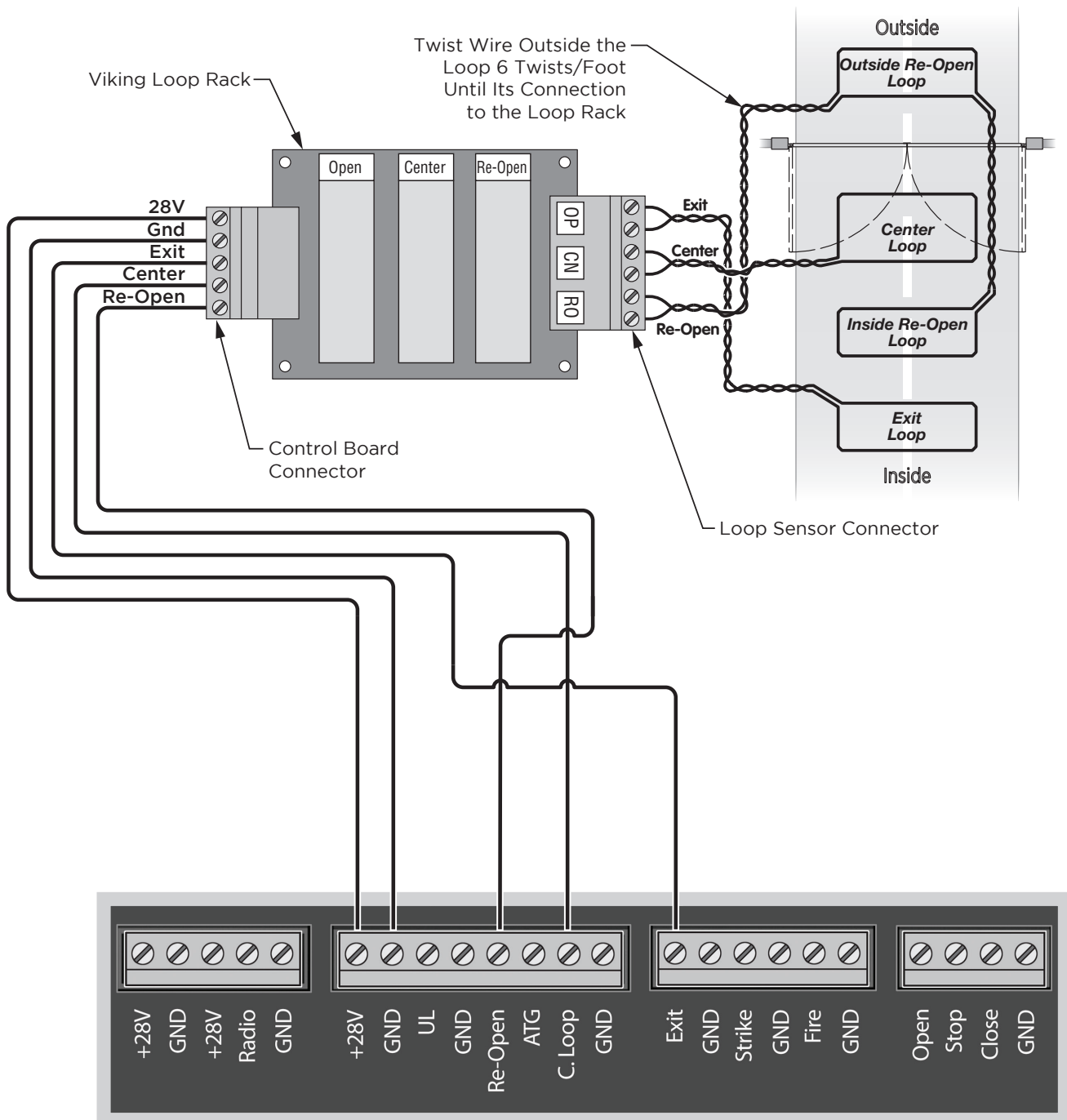



# ACCESSORY CONNECTIONS

## Guidelines for Loop Installation

1. Prevent sharp corners in the geometry of the loop sensor.
2. Install the appropriate number of turns for your loop geometry based on the loop perimeter. Use the Table below as a guide.
3. Use XLP (cross-linked-polyethylene) type of wire. This wire reduces the effects of moisture and other environmental events in altering the functionality of the vehicular loop detector.
4. Twist the lead wire at least 6 turns per foot.
5. Use BACKER-ROD to minimize damage to the loop detector wire prior to using the sealant.
6. Place the loop detector wire and adjust the sensitivity of the vehicular loop detector unit as needed.

**⚠ IMPORTANT!** Some of the following parameters may affect the proper functionality of the vehicular loop detector.

**Consult the manufacturer of the vehicular loop detector and/or loop wire.**

- Gate size
- Number of turns in the loop sensor wire
- Distance of the loop sensor wire to the gate

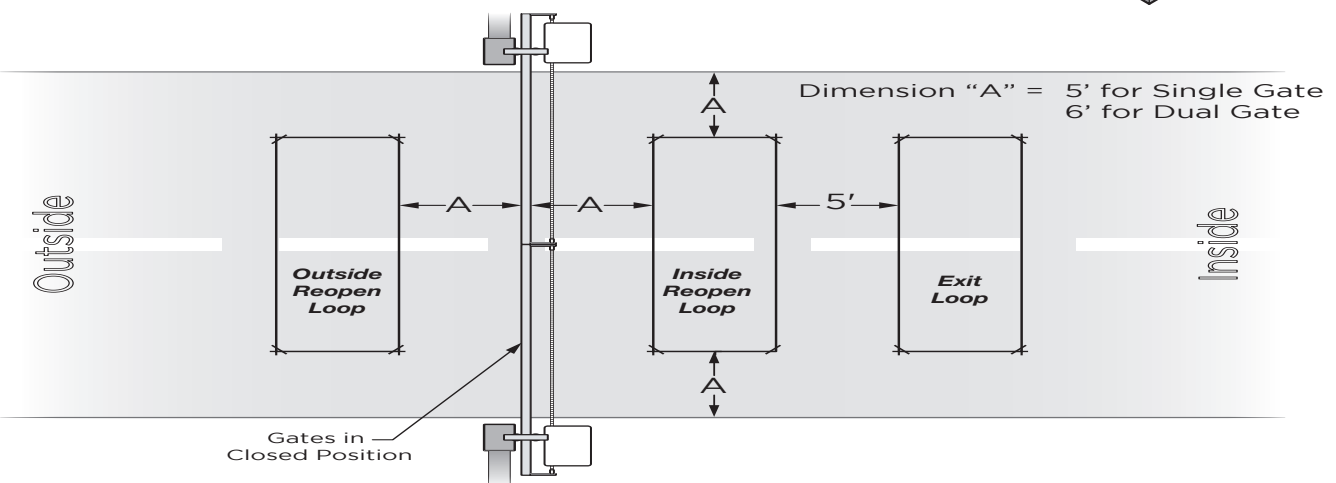
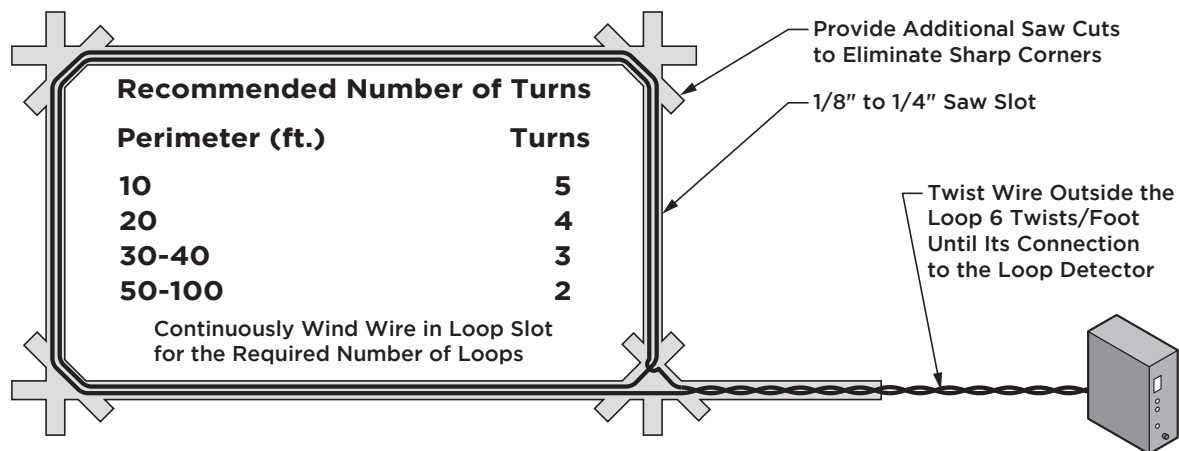
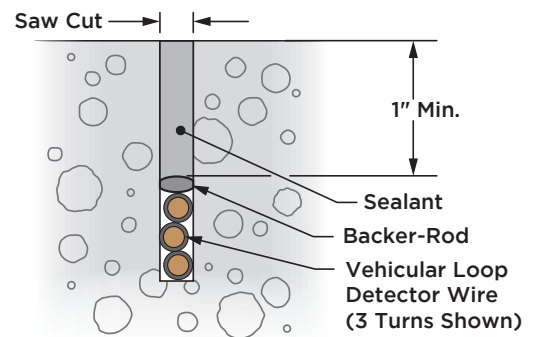

# ACCESSORY CONNECTIONS

## Magnetic Lock, Lock Solenoid

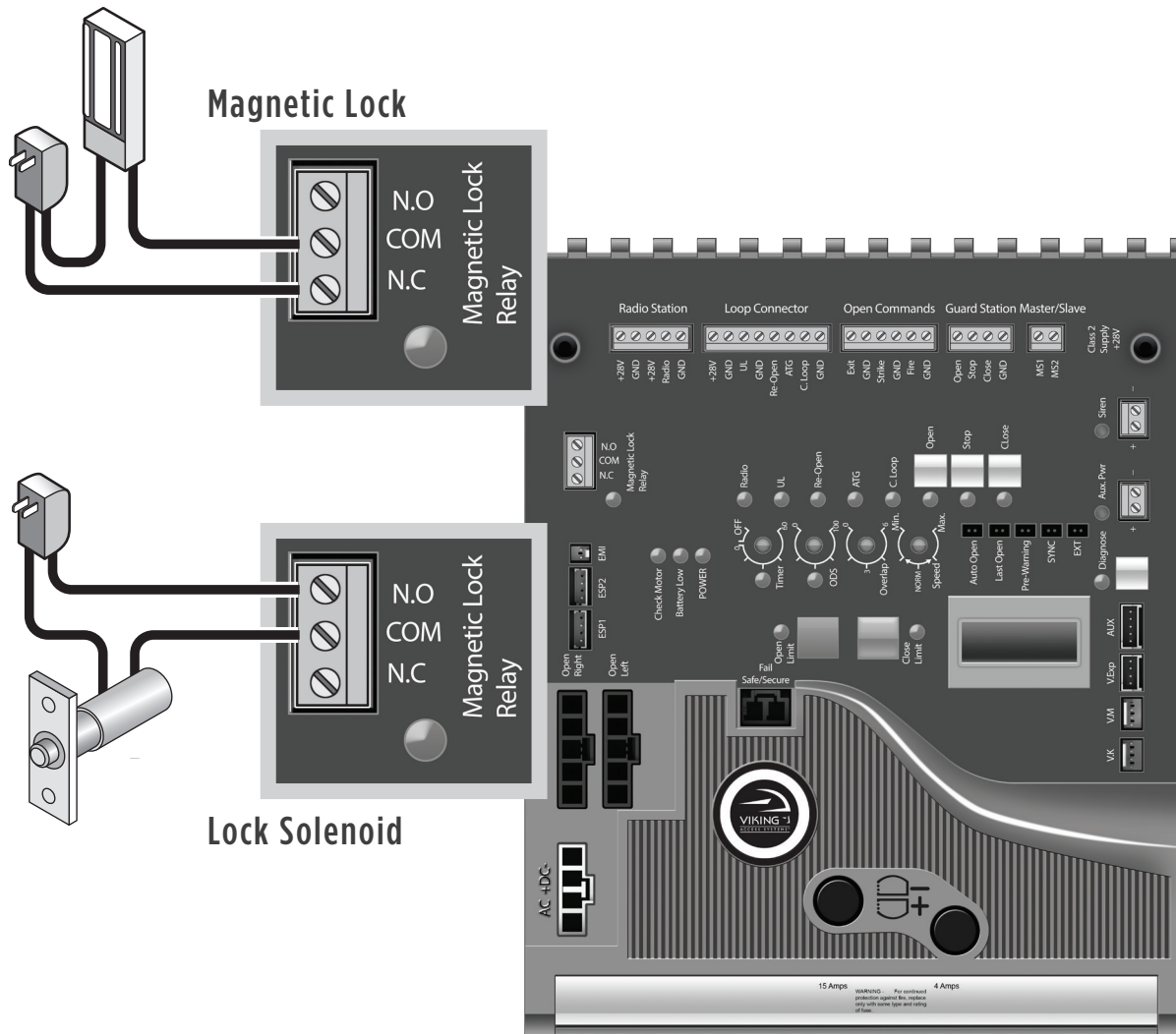

### Power for the Locks:

Do not use the 24VDC power supplied by the Control Board. A Class 2 external power supply or plug-in transformer, must be used for the magnetic lock or lock solenoid. This will prevent rapid drainage of the battery in the event of power failure.

The control boards “Magnetic Lock” relay is rated for 10A-250VAC.

**⚠ TECHNICAL TIP:** The Magnetic Lock Relay LED will indicate status of the on-board relay even if a lock is not connected to the Control Board. Refer to page 34.

# ACCESSORY CONNECTIONS

## Barrier Arm Synchronization

**NOTE:** The Control Board provides a convenient solution for applications that require synchronized operation with a Barrier Arm Operator. Consult the Barrier Arm operator's documentation for further instructions.

This type of application opens and closes in the following pattern:

1. Open Command is provided only to the Barrier Arm operator.
2. The Barrier Arm will send an open input to the Viking gate operator; Barrier Arm will delay to open until the Viking gate operator reaches its Open Limit.
3. Barrier Arm will close first; the Viking gate operator will delay to close until the Barrier Arm reaches its Close Limit.

### STEP 1 (Figure A)

At the Barrier Arm operator, connect the device(s) that will be used as the primary OPEN input.

### STEP 2

Connect the Barrier Arms' designated sync output terminals to the Strike input at the Viking gate operator.

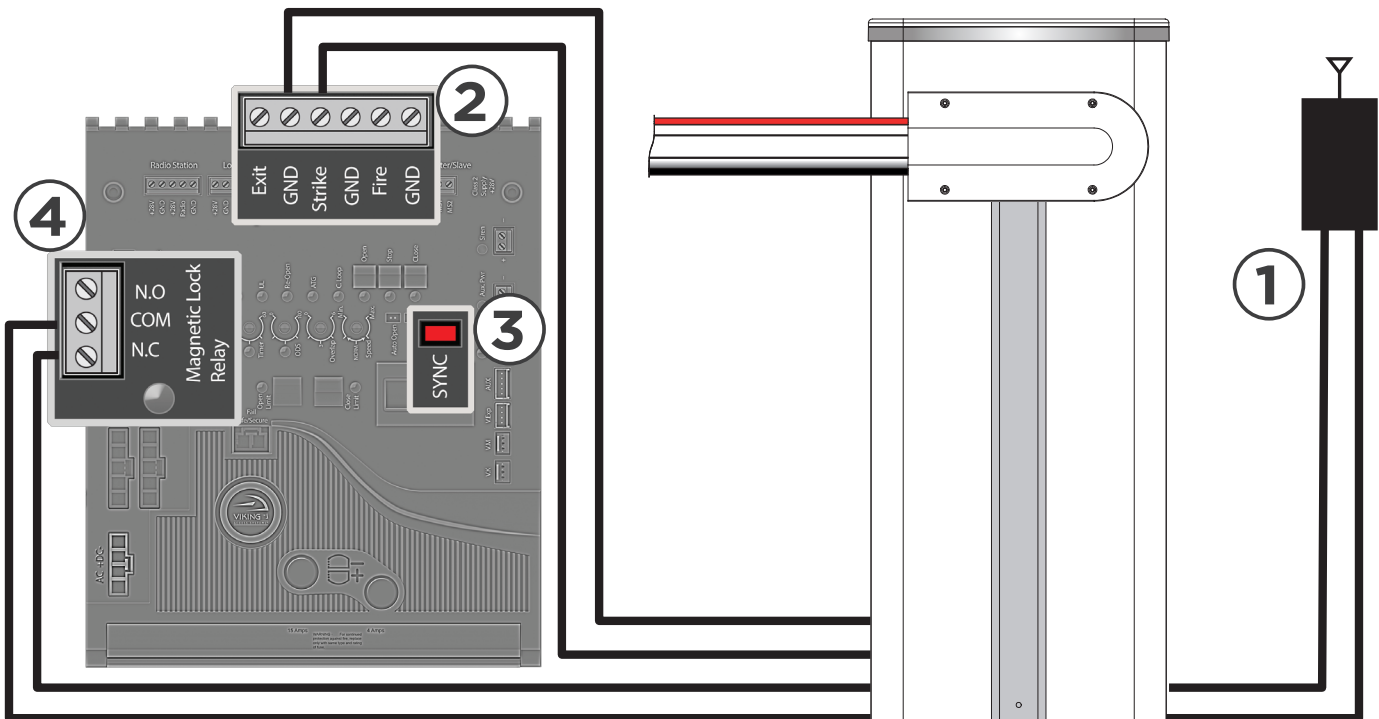

### STEP 3

At the Viking gate operator, activate Sync Mode by placing a jumper on to the pin headers labeled "SYNC".

### STEP 4

Connect Magnetic Lock relay terminals ("COM" and "N.C.") to the Barrier Arms' designated sync input terminals.

# TROUBLESHOOTING

## LED References

In addition to the LCD Display, the Control Board LEDs monitor the various circuits of the Control Board. Use the table below to identify the corresponding “TS Ref#” and refer to page 34-40 for further troubleshooting.

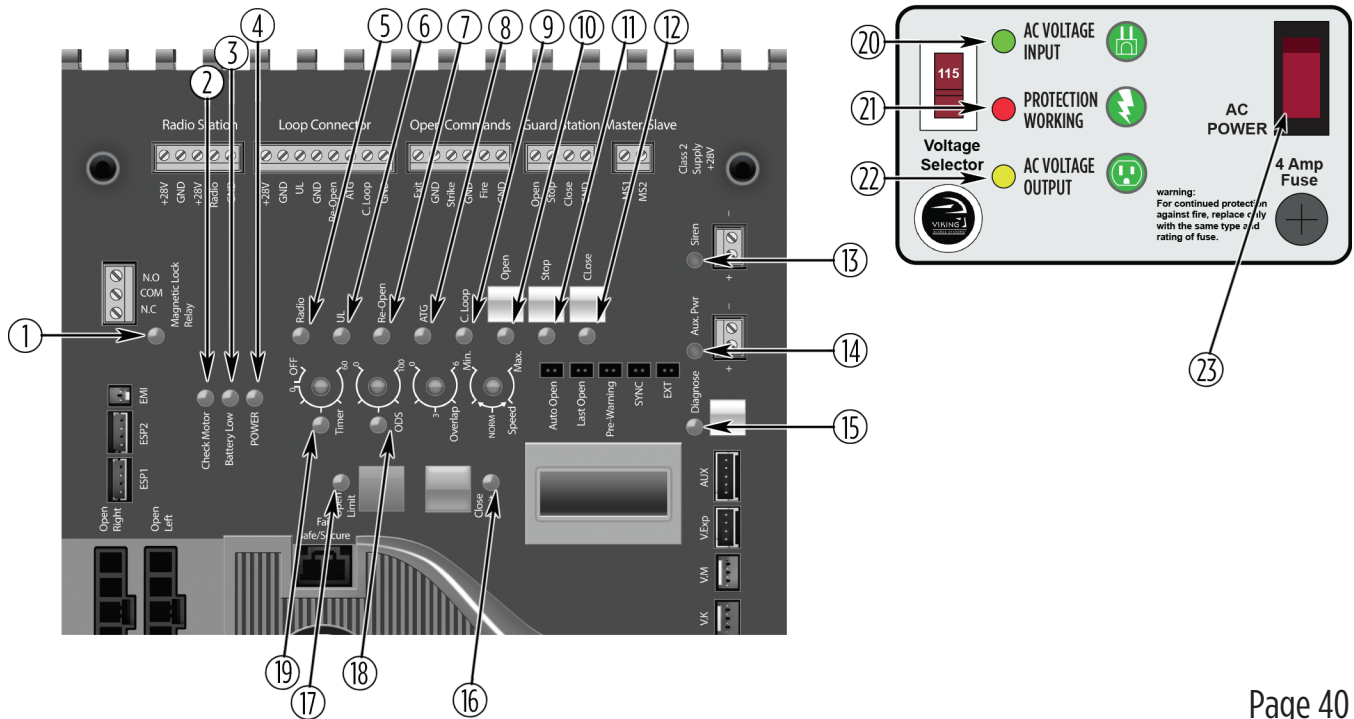

#	LED	Status	Meaning	TS Ref#(s)
1	"Magnetic Lock Relay"	OFF	At Closed Limit and Magnetic Lock Relay state is closed across "COM" & "N.C.". (pg 32). Gate should be at the Close Limit.	
		SOLID	Not at Closed Limit and Magnetic Lock Relay state is closed across "COM" & "N.O.". (pg 32). Gate should not be at the Close Limit	
2	"Check Motor"	OFF	Normal Condition.	
		SOLID	The Control Board is sending power to the motor but the circuit is open.	7, 8
3	"Battery Low"	OFF	Normal Condition.	
		SOLID	Batteries are low. Check power supply to the operator. (pg 16-17).	1, 2, 3
		FLASHING	Batteries critically low. Check power supply to the operator. (pg 16-17).	1, 2, 3
4	"POWER"	SOLID	Normal Condition.	
		FLASHING	Operator is running on batteries only (pg 16-17).	1, 2
		OFF	No power to Control Board.	1, 2, 4, 5
5	"Radio"	OFF	Normal Condition.	
		SOLID	Control Board is receiving an input from a device connected to the Radio terminal (pg 26, 28).	9, 10
6	"UL"	OFF	Normal Condition.	
		SOLID	Control Board is receiving an input from a device connected to the UL terminal or when more than one device is connected (pg 6-7, 18, 26).	9, 10, 16, 20
7	"Re-Open"	OFF	Normal Condition.	
		SOLID	Control Board is receiving an input from a device connected to the Re-Open terminal or when more than one device is connected (pg 6-7, 18, 26, 30).	9, 10, 16, 20
8	"ATG"	OFF	Normal Condition.	
		SOLID	Control Board is receiving an input from a device connected to the ATG terminal (pg 26).	9, 10

# TROUBLESHOOTING

## LED References

Pg 40  
TS Ref#(s)

#	LED	Status	Meaning	
9	"C Loop"	OFF	Normal Condition.	
		SOLID	Control Board is receiving an input from a device connected to the C Loop terminal (pg 26, 30).	9, 10
10	"Open"	OFF	Normal Condition.	
		SOLID	Control board is receiving an input from a device connected to any of the following input terminals: Exit, Fire, Strike or Open (pg 26, 30).	9, 10
11	"STOP"	OFF	Normal Condition.	
		SOLID	Control Board is receiving an input from a device connected to the Stop terminal (pg 26).	9, 10
			There is a problem with the required monitored sensor(s) connected to the "UL" and/or "Re-Open" input terminals (pg 6-7, 18)	16, 20
			There is a problem with both the SPS and EPS2 Sensors or wires.	14, 17, 24, 25
		The SPS is connected properly, but the installed Control Board is not configured for SPS.	?	
12	"Close"	OFF	Normal Condition.	
		SOLID	Control Board is receiving an input from a device connected to the Close terminal (pg 26).	9, 10
13	"Siren"	OFF	Normal Condition.	
		SOLID	Second consecutive obstruction has been detected. (pg 22, 24).	1, 2, 11, 13
		FLASHING	Batteries are critically low.	1, 2
14	"Aux. Pwr"	OFF	No voltage output on these terminals at the moment.	
		SOLID	There is 24VDC output on these terminals at the moment.	
15	"Diagnose"	OFF	Normal Condition.	
		FLASHING	Errors have been detected; Check LCD Display for ERR messages (pg 38-39).	
16	"Close Limit"	OFF	Gate is not at the close limit position.	
		SOLID	Gate is at the close limit position.	
		FLASHING	Close limit position has been erased or not set (pg 19).	23
17	"Open Limit"	OFF	Gate is not at the open limit position.	
		SOLID	Gate is at the open limit position.	
		FLASHING	Open limit position has been erased or not set (pg 19).	23
18	"ODS"	OFF	Normal Condition.	
		SOLID	Obstruction has been detected. (pg 24).	1, 2, 11, 13
		FLASHING	Overload has been detected. (pg 24).	1, 2, 11, 13
19	"Timer"	OFF	If gate is at the open limit, the Timer to close is turned OFF. (pg 22)	
		SOLID	Timer to close is ON and counting down to close the gate. (pg 22)	
		FLASHING	Timer is ON but is not timing out due to a conflicting command. (pg 22)	9, 10
20	"AC VOLTAGE INPUT"	SOLID	Normal Condition.	
		OFF	Incoming power to Power Supply Panel Assembly is not sufficient.(pg 16).	1
21	"PROTECTION WORKING"	SOLID	Normal Condition.	
		OFF	EMI Board is damaged and circuit is not protected . Replace EMI Board.	
22	"AC VOLTAGE OUTPUT"	SOLID	Normal Condition.	
		OFF	There is no output voltage from the Power Supply Panel Assembly.	2
23	"AC POWER"	SOLID	Normal Condition for High Voltage installations.	
		OFF	High Voltage is not supplied to the Modular Power Box (pg 16).	1

# TROUBLESHOOTING

## LCD Display References

The Control Board is equipped with a LCD Display that provides operator information, current conditions, settings, diagnostics and error messages. Use the table below to identify the corresponding “TS Ref#” and refer to pages 34-40 for further troubleshooting.

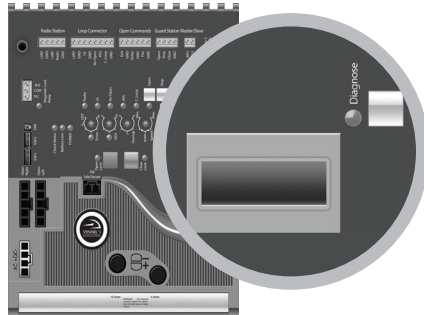

**Press the Diagnose button to manually scroll through all of the Messages.**

**NOTE:** Error Messages will be displayed first. The “Diagnose” LED will flash consecutively indicating how many Error Messages are available.

Page 40  
TS Ref #s

LCD MSG	Meaning
MODEL H-10 SPS	Indicates the Model of the unit

### System Status Messages

GATE IS IDLE	Gate is stopped between limits	
GATE IS OPENING	Gate is opening	
GATE IS CLOSING	Gate is closing	
GATE IS OPENED	Gate is at the limit open position	
GATE IS CLOSED	Gate is at the limit close position	
STOP BY OBSTRUCT	Gate has stopped due to an obstruction of the gate system. Also refer to the “ODS” LED. (pg 22, 24, 34)	11, 12, 13
STOP BY OVERLOAD	Gate has stopped due to an overload of the gate system. Also refer to the “ODS” LED. (pg 22, 24, 34)	11, 12
HOLDING ... SEC	Gate is at the limit open position and timing to close - The display shows the actual time left before closing	
RED CONN UNPLUGED	The Motor Connector is not plugged into the red Open Left or Open Right socket at the Control Board. (pg 19)	21

## LCD Display References

LCD MSG	Meaning	
EPS2	Status of the EPS2 Sensor. "OK" = EPS2 Sensor signal is good but is the only sensor controlling the limits. "STANDBY" = EPS2 is monitoring the limit positions secondarily to SPS Sensor. "MISSING" = EPS2 Sensor is disconnected from the Control Board. (pg 11 @6). "NOT SET" = EPS2 Sensor was reconnected. Clear and Reset both limits. (pg 19)	14
SPS	Status of the SPS Sensor. "OK" = SPS Sensor signal is good and controlling the limit positions . "LEARNING" = SPS Sensor is performing a learn cycle. "MISSING" = SPS Sensor is disconnected from the Control Board (pg 11 @24).	17

## Multi Meter Displays

MOT AMP ---- A	This is the motor current amperage during operation
MOT VOLT ---- VDC	This is the actual motor voltage during operation
AC VOLT ---- VAC	This is the actual low voltage AC to the Control Board from the transformer
CHARGE ---- VDC	Indicates the charging voltage to the batteries, if the Battery Switch is in the OFF position.
BAT VOLT ---- VDC	Indicates battery voltage, if the AC power is discontinued to the Control Board.

## Board Settings Messages

SPEED -- %	Shows the percentage of speed set by the Speed adjustment on the Control Board. (pg 22)
OBS SENS ---- %	Shows the force setting selected to trip the obstruction sensor. (pg 22, 24)
TIMER -- SEC	Shows the amount time set or remaining to hold the gate at the Open Limit position, before the gate starts to close. (pg 22)
HEATER ---- OFF	The Integrated Heater is disabled for the open "OPN" and/or close "CLS" limits (pg 25)
HEATER ---- ON	The Integrated Heater has been enabled to turn on at the open "OPN" and/or close "CLS" limits (pg 27) "ACTV" will also be displayed while it is heating.
LOCK MOD ----	The Lock Mode feature is turned ON or OFF (pg 25)
UL LEARN UL_ RO_	Indicates the number of connected Monitored Entrapment Protection Sensors that are being monitored. NO LEARN = no sensors learned. (pg 6-7, 18)

# TROUBLESHOOTING

## LCD Display References

Page 40  
TS Ref #s

LCD MSG	Meaning	
<b>Error Messages</b>		
ERR AC LOW	Indicates that the 24VAC supply to the VFlex Board is too low from the 115/230 power supply.	1, 3, 19
ERR AC HIGH	Indicates that the 24VAC supply to the VFlex Board is too high from the 115/230 power supply.	1, 3, 19
ERR AC NO AC	Indicates that there is no 24VAC supply detected to the VFlex Board from the 115/230 power supply.	1, 2, 4, 19
ERR CHRG HIGH	Potential problem with the charging voltage from the Control Board.	1, ?
ERR CHRG CHECK 4A	a) 4 Amp Fuse is blown at the Control Board or; b) There is a problem with the batteries or the Control Board.	18, ?
ERR BAT LOW	The voltage from the batteries is low.	1, 2, 3, 4, 18
ERR FUSE 20 AMP	20 Amp motor fuse is blown.	7, 11, 12
ERR ---- LIMIT	Indicates that the open "OPN", close "CLS" or both "NO" limits are cleared and need to be set.	23
ERR EMI NO EMI	No EMI board detected.	15
ERR EMI NO FUSE	4 Amp main fuse is blown on Power Supply Panel Assembly.	2
ERR EMI NO AC	There is no AC voltage detected at the Power Supply Panel Assembly.	1, 4
ERR EMI UNKNOWN	There is a problem with the communication between the EMI Board and the VFlex Board.	15
ERR EMI PROTECT	Lightning strike protection for the EMI Board (behind the Power Supply Panel Assembly) needs to be replaced	?
ERR REFV WRONG	One, or more, of the Control Board internal reference voltages are incorrect.	?
ERR SENS UL RO	There is a problem with the required monitored sensor(s) connected to the "UL" and/or "Re-Open" input terminals (pg 6-7, 18).	20



## LCD Display References

LCD MSG	Meaning	
<b>Error Messages</b>		
ERR EPS2 WRONG	The EPS2 communication cable has a connection problem or damaged.	14
ERR EPS2 MISSING	The Control Board does not see any data from the EPS Sensor.	14
ERR SPS MISSING	The Control Board does not see any data from the SPS Sensor. Note: For earlier year model operators not equipped with SPS Sensor, this error is normal and expected.	17
ERR SPS DRIVE	The SPS Sensor is not detecting any movement while the motor is expected to be running.	24
ERR SPS SENSING	The SPS PCB is not detecting the SPS Gearbox	25
ERR SPS SV	5VDC power supply to the SPS PCB is out of range 4.7VDC - 5.3VDC.	26

# TROUBLESHOOTING

## Solutions

Begin the troubleshooting process by referring to the error messages on the LCD Display and/or the Status LEDs on the Control Board. Use pages 34-39 to identify the Troubleshooting Reference # (TS Ref#) then reference the table below.

TS Ref#	CHECK	Page Ref#
1	Check that the high voltage power supplied to “J-Box” is within range. 100V-120V or 200V-240V	pg 16-17
2	At the Power Supply Panel Assembly, remove and check 4A Fuse for continuity.	pg 16-17
3	Check that the “Voltage Selector”, on the Power Supply Panel Assembly, is set according to the high voltage power supply. 115VAC or 230VAC	pg 16-17
4	Check the main power breaker and “AC POWER” switch (if applicable) are on.	pg 16-17
5	Check that the Power Harness is connected to the Control Board.	pg 11, 16-17
6	Not applicable to this model.	
7	Check Motor Fuse on the Control Board.	pg 11
8	Check for an open circuit to the Motor and that the operator is not in Manual Release mode.	pg 7, 10
9	Check the Status LEDs and LCD Display to determine if the Control Board is receiving an input from any external devices or if the “ODS” has been triggered.	pg 22, 24, 34-36
10	Remove the external devices from the Control Board to determine if the Control Board is responding to an input or problem with the external device or wiring.	pg 26-30, 34-35
11	Check the “ODS” setting on the Control Board.	pg 4, 22, 24
12	Check that the gate can be moved manually with low resistance throughout its full length of travel. Check gate track rollers, chain and hinges as applicable.	pg 4, 7
13	Check the limit position.	pg 19
14	Check the EPS2 cable for damage and is securely connected to the “EPS2” connector at the Control Board. Clean the connection pins.	pg 10-11
15	Check the EMI Cable and contacts between the EMI Board and the VFlex Board.	pg 11
16	Check that the LCD Display for Error Messages	pg 38, 39
17	Check that the SPS cable is securely connected to the “V.Exp” connector at the Control Board. Remove the SPS harness from “V.Exp” clean the connection pins. Check for 4.7VDC - 5.3VDC on “V.Exp” across pins 1 & 4.	pg 10-11
18	Check 4 Amp fuse on the Control Board	pg 11
19	Check for 24VAC out from the Toroidal Transformer and Power Harness.	pg 16-17
20	Check the required entrapment protection sensors.	pg 3, 6-7, 18
21	Check that the Motor Harness Connector is connected to the Control Board.	pg 11, 19
22	Not applicable to this model.	
23	Set or reset the limit position electronically from the Control Board.	pg 19
24	Check that the Motor is responding to commands. Check that the SPS Gearbox and Coupler are properly connected to the Motor Gearbox. Check that the Motor is secured to the Motor Gearbox and the coupling key is in place.	pg 10-11
25	Check that the SPS PCB is installed properly on the SPS Gearbox and that the pickup contacts are not contaminated.	pg 10-11
26	Check for 4.7VDC - 5.3VDC on SPS Cable across Red and Black wires at “V.Exp” and at SPS PCB. Check the SPS Cable is connected properly at both ends and for damage.	pg 10-11
?	Call Viking Technical Support for further assistance.	

# PARTS DIAGRAM:

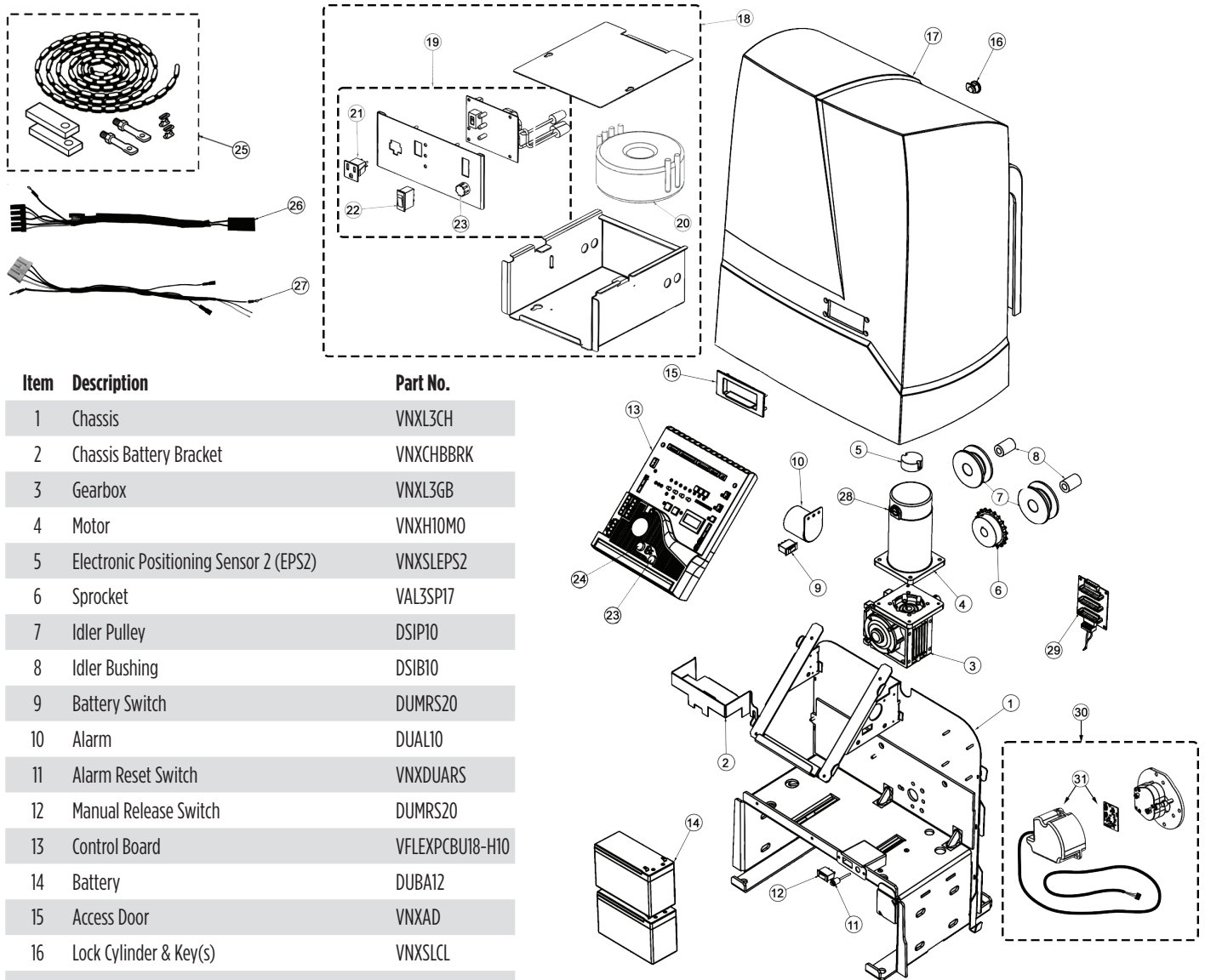

Item	Description	Part No.
1	Chassis	VNXL3CH
2	Chassis Battery Bracket	VNXCHBRK
3	Gearbox	VNXL3GB
4	Motor	VNXH10M0
5	Electronic Positioning Sensor 2 (EPS2)	VNXSLEPS2
6	Sprocket	VAL3SP17
7	Idler Pulley	DSIPI0
8	Idler Bushing	DSIB10
9	Battery Switch	DUMRS20
10	Alarm	DUAL10
11	Alarm Reset Switch	VNXDUARS
12	Manual Release Switch	DUMRS20
13	Control Board	VFLEXPCBU18-H10
14	Battery	DUBA12
15	Access Door	VNXAD
16	Lock Cylinder & Key(s)	VNXSLCL
17	Operator Cover	VNXCV
18	Modular Power Box Assembly	VNXMPB
19	Power Box Panel Assembly	VNXUPBPA
20	Toroid Transformer - 15 amp	DUTT15
21	120V Receptacle	VA120PL
22	120VAC Power Switch	DUMRS10
23	Fuse - 4 amp	VNXF4A
24	Fuse - 20 amp	VNXF20A
25	25' #40 Chain Kit, Nickel Coated	VAL3CKN
26	Motor Harness	VNXH10MH
27	Power Harness	VNXL3PH
28	Brush Kit	VAMOBK
29	Loop Rack	VA-LR
30	Smart Position Sensor (SPS)	VASPSL3H10NX
31	SPS PCB Assembly	VSPSPCBK

# LIMITED WARRANTY

FAAC International, Inc. (“Seller”) warrants the first Purchaser of the product to be free from defects in material and workmanship for a specific period as defined by the Warranty Disclosure on the website [www.vikingaccess.com](http://www.vikingaccess.com). The Warranty Period commences from the date of invoice.

Control Boards, Accessories or Spare Parts factory installed or sold with any of the products above carry the same warranty period as the product they are sold with, excluding batteries that carry a maximum 2 year warranty.

Accessories or spare parts sold separately have a 1-year warranty period.

Products repaired under warranty carry the remainder of the original warranty period. For products repaired outside of warranty, the Seller warrants that all parts used for the repair will be free from defects in materials and workmanship for a period of ninety (90) days.

Defective products must be returned to Seller, freight prepaid by Purchaser, within the warranty period. A Return Material Authorization Number (RMA) must be obtained before product is returned. Items returned will be repaired or replaced, at Seller’s option, upon an examination which discloses to the satisfaction of the Seller that the item is defective. The Seller will return the warranted item freight prepaid.

This limited Warranty covers the product under the normal use and service for which it was intended, provided it has been properly installed and operated. Seller’s obligations under this warranty shall be limited to the repair or exchange of any part. This warranty shall not apply to products or parts thereof which have been repaired or altered, without Seller’s written consent, outside of Seller’s workshop or altered in any way so as, in the judgment of Seller, to affect adversely the stability or reliability of the product(s) or has been subject of misuse, negligence, or accident, or has not been operated in accordance with the product’s instructions or has been operated under conditions more severe than, or otherwise exceeding, those set forth in the specifications for such product(s).

When the warranty service involves the exchange of an operator or part, the item the Seller replaces becomes its property and the replacement becomes Purchaser’s property. The Purchaser represents that all removed items are genuine and unaltered. The replacement may not be new but will be in good working order and at least functionally equivalent to the item replaced. The replacement assumes the warranty service status of the replaced item.

The products are not warranted to meet the specific requirements, if any, of safety codes of any particular state, municipality, or other jurisdiction, and the Seller doesn’t assume any risk or liability whatsoever resulting from the use thereof, whether used singly or in combination with other machines or apparatus.

The Seller does not assume nor authorizes any person to assume for them any other liability in connection with the sale or use of the products of beyond that extended herein.

The warranty hereinabove set forth shall not be deemed to cover maintenance parts, including, but not limited to hydraulic oil, motor brushes, or the like. No agreement to replace or repair shall constitute an admission by the Seller of any legal responsibility to effect such replacement to make such repair, or otherwise.

All products sold by the Seller are subject to design and/or appearance modifications, which are production standards at the time of shipment. The Seller may, but shall not be required to, modify or update products shipped prior to a current production standard.

**THIS WARRANTY IS EXPRESSLY IN LIEU OF ALL OTHER WARRANTIES EXPRESSED OR IMPLIED INCLUDING THE WARRANTIES OF MERCHANTABILITY AND FITNESS FOR USE. THIS WARRANTY SHALL NOT APPLY TO PRODUCTS OR ANY PART THEREOF WHICH HAVE BEEN SUBJECT TO ACCIDENT, NEGLIGENCE, ALTERATION, ABUSE, OR MISUSE OR IF DAMAGE WAS DUE TO IMPROPER INSTALLATION OR USE OF IMPROPER POWER SOURCE, OR IF DAMAGE WAS CAUSED BY FIRE, FLOOD, LIGHTNING, ELECTRICAL POWER SURGE, EXPLOSION, WIND STORM, HAIL, AIRCRAFT OR VEHICLES, VANDALISM, RIOT OR CIVIL COMMOTION, OR ACTS OF GOD.**

The Seller shall not be liable for any loss or damage whatsoever resulting, directly or indirectly, from the use or loss of use of the product(s). Without limiting the foregoing, this exclusion from liability embraces a Purchaser's expenses for downtime or for making up downtime, lost profit, damages for which the Purchaser may be liable to other persons, damage to property, and injury to or death of any persons.

This limited warranty extends only to wholesale customers who buy directly through the Seller's normal distribution channels. The Seller does not warrant its products to end consumers. Consumers must inquire from their selling dealer as to the nature and extent of that dealer's warranty, if any.

**THE LIMITED WARRANTY OFFERED HEREIN IS THE SOLE AND EXCLUSIVE REMEDY AVAILABLE TO THE PURCHASER. CORRECTION OF DEFECTS, IN THE MANNER AND FOR THE PERIOD OF TIME DESCRIBED HEREIN, SHALL CONSTITUTE THE COMPLETE FULFILLMENT OF ALL LIABILITIES OF SELLER TO THE PURCHASER WITH RESPECT TO THE COVERED PRODUCT, AND SHALL CONSTITUTE FULL SATISFACTION OF ALL CLAIMS, WHETHER BASED ON CONTRACT, NEGLIGENCE, STRICT LIABILITY OR OTHERWISE. IN NO EVENT SHALL SELLER BE LIABLE FOR ANY LOSS OF PROFITS OR ANY INDIRECT, CONSEQUENTIAL, INCIDENTAL, SPECIAL OR PUNITIVE DAMAGES ARISING OUT OF SELLER'S BREACH OF THIS LIMITED WARRANTY, OR ARISING OUT OF THE CUSTOMER'S INABILITY TO USE THE COVERED PRODUCT, EVEN IF SELLER HAS BEEN ADVISED OF THE POSSIBILITY OF SUCH DAMAGES.**

Some states do not allow the exclusion or limitation of incidental or consequential damages, so the above limitation may not apply to a particular Purchaser. This Limited Warranty gives the Purchaser specific legal rights. The Purchaser may also have other rights, which vary from state to state.

# VIKING EXPANSION PRODUCTS



**VIKING KONNECT Primary/Secondary Kit** Secure and reliable Primary/Secondary communication between two single gate operators or ECU's using Viking's Konnect technology.

**Part# VA-KONNECT-MS**

\*\*\*Q-7 & ECU Operators require (2) Antenna Extension Cables (part# VA-RPSMA)\*\*\*

\*\*\* NOT COMPATIBLE for Solar Mode setting on Control Board (if applicable)\*\*\*



**VIKING MONITOR** Off-site access to operator diagnostics. With the Viking Monitor App, this tool allows you to monitor and label multiple operators by site and location for quick reference. Provides error notifications, operator status, settings and diagnostic information.

**Part# VA-MONITOR**

\*\*\*Q-7 & ECU Operators require (1) Antenna Extension Cable (part# VA-RPSMA)\*\*\*



**VIKING AC SURGE PRO** Adds another layer of protection to the high voltage power supply of your gate operator. Connecting the AC Surge Pro in parallel to the EMI Board, provides a dual layer of protection from surges up to 20,000 Volts / 10,000 Amps. **Part# VA-SURGEPROAC**



**VIKING 24V SOLAR KIT** The components included in this package are intended to provide sufficient power for general applications.

**Part# VA-SOCHP**

**This Kit includes the following components:**

- |     |                             |   |
|-----|-----------------------------|---|
| (2) | <b>12V 40W Solar Panels</b> | Part# VA-S040W <b>(wired in series = 24V 80W)</b> |
| (2) | <b>12V 35Ah batteries</b>   | Part# DUBA35 <b>(wired in series = 24V 35Ah)</b>  |
| (1) | <b>Solar Charger</b>        | Part# SOCHR10                                     |
| (1) | <b>Solar Power Harness</b>  | Part# SOHAR                                       |

**⚠ NOTE:** The number of cycles achieved from this kit are dependent upon the following and may require increased panel and battery capacities:

- Power consumption of all accessories being used
- Average solar radiation of geographic location

# OUR CONTINUOUS COMMITMENT TO EXCELLENCE

Viking Access Systems is continuously working hard to identify and design products that will appeal to the industry and its needs. As technology continues to advance, we have developed a completely efficient and intelligent line of gate operators to meet the changing demands. These machines offer: full UL325 and UL991 compliance, soft-start and soft-stop, intelligent obstruction sensors, continuous operation (100% duty cycle) and extreme power efficiency. Innovative features include: adaptive and self-learning algorithms, redundancy design in both hardware and software to ensure operation and functionality, protection from lightning, short circuit and power surges, and our exclusive helical gearing offering the highest efficiency rating in the industry. Our entire product line is continually modified and improved based on the latest technology and our customer's valuable feedback. The results are products that offer accuracy, efficiency, reliability and performance, all in sleek, high-tech designs.

We pledge to continue establishing ourselves as the leader in high quality, innovative gate operators by developing "Next Level" technology. We are committed to providing safety and convenience with innovative solutions for every security gate need.



VIKING ACCESS SYSTEMS™

VIKING ACCESS SYSTEMS™

VIKING ACCESS SYSTEMS™

INSTALLATION DATE: \_\_\_\_\_

COMPANY / INSTALLER: \_\_\_\_\_

CONTACT: \_\_\_\_\_

SERIAL NUMBER(S): \_\_\_\_\_

ALL INSTALLATION, MAINTENANCE AND REPAIR WORK MUST BE DOCUMENTED AND MADE AVAILABLE TO THE USER.



**VIKING ACCESS SYSTEMS**

631 Wald Irvine, CA 92618

Phone 800.908.0884

Fax 949.753.1640

[www.vikingaccess.com](http://www.vikingaccess.com)

